

NZS 4121:2001

New Zealand Standard

Design for Access and Mobility – Buildings and Associated Facilities

Superseding NZS 4121:1985 and NZMP 4122:1989



NZS 4121:2001



Single User PDF Terms & Conditions

You have material which is subject to strict conditions of use. Copyright in this material is owned by the New Zealand Standards Executive. Please read these terms and conditions carefully, as in addition to the usual range of civil remedies available to Standards New Zealand on behalf of the New Zealand Standards Executive for infringement of copyright, under New Zealand law every person who infringes copyright may be liable to a fine of up to \$10,000 for every infringing copy or imprisonment of up to 5 years, or a fine of up to \$150,000 or imprisonment not exceeding 5 years.

You have access to a single-user licence to read this non-revisable Adobe Acrobat PDF file and print out and retain ONE printed copy only.

We retain title and ownership of the copyright in this PDF file and the corresponding permitted printed copy at all times.

Under this license use of both the PDF file and the single permitted printed copy of this PDF file you may make are restricted to you. Under no circumstances are you permitted to save, sell, transfer, or copy this PDF file, the one permitted printed copy of this PDF file, or any part of either of them.

You undertake that you will not modify, adapt, translate, reverse engineer, decompile, disassemble or create derivative works based on any of the downloaded PDF file, nor will you merge it with any other software or document, even for internal use within your organization.

Under no circumstances may this PDF file be placed on a network of any sort without our express permission.

You are solely responsible for the selection of this PDF file and any advice or recommendation given by us about any aspect of this PDF file is intended for guidance only and is followed or acted upon entirely at your own risk.

We are not aware of any inherent risk of viruses in this PDF file at the time that it is accessed. We have exercised due diligence to ensure, so far as practicable, that this file does not contain such viruses.

No warranty of any form is given by us or by any party associated with us with regard to this PDF file, and you accept and acknowledge that we will not be liable in any way to you or any to other person in respect of any loss or damage however caused which may be suffered or incurred or which may arise directly or indirectly through any use of this PDF file.

Regardless of where you were when you received this PDF file you accept and acknowledge that to the fullest extent possible you submit to New Zealand law with regard to this licence and to your use of this PDF file.

Copyright Standards New
Zealand

NZS 4121:2001

COMMITTEE REPRESENTATION

This Standard was prepared by the Access 2000 committee (P 4121) for the Standards Council established under the Standards Act 1988.

The committee consisted of representatives of the following:

Building Industry Authority
Building Officials Institute of New Zealand
DPA NZ (Inc)
New Zealand Association of Occupational Therapists
New Zealand Institute of Architects
Property Council of New Zealand

Working in close co-operation with:

Association for Blind Citizens
Barrier Free New Zealand Trust
National Foundation for the Deaf
Royal New Zealand Foundation for the Blind

ACKNOWLEDGEMENT

This project was funded by the Building Industry Association as part of its strategy to provide guidance for those who are responsible for making buildings and facilities accessible to, and fully usable by people who have disabilities. The contribution of time by the above listed representatives is acknowledged. Standards New Zealand recognizes the contribution made by Quentin Angus, MBE LIB and all those who have provided valuable time and input into the development and revision of this Standard.

© COPYRIGHT

The copyright of this document is the property of the Standards Council. No part of it may be reproduced by photocopying or by any other means without the prior written permission of the Chief Executive of Standards New Zealand unless the circumstances are covered by Part III of the Copyright Act 1994.

Standards New Zealand will vigorously defend the copyright in this Standard. Every person who breaches Standards New Zealand's copyright may be liable to a fine not exceeding \$50,000 or to imprisonment for a term not to exceed three months. If there has been a flagrant breach of copyright, Standards New Zealand may also seek additional damages from the infringing party, in addition to obtaining injunctive relief and an account of profits.

Published by Standards New Zealand, the trading arm of the Standards Council, Private Bag 2439, Wellington 6020.

Telephone: (04) 498 5990, Fax: (04) 498 5994.

Website: www.standards.co.nz

AMENDMENTS

No	Date of issue	Description	Entered by, and date

CONTENTS

Committee representation IFC
 Acknowledgement IFC
 Copyright IFC
 Related documents 5
 Review of Standards 6
 Foreword 7

Section

1 GENERAL 9
 1.1 Scope 9
 1.2 Objective 10
 1.3 Application 11
 1.4 Statutory provisions 11
 1.5 Definitions and interpretation 12

2 PERFORMANCE REQUIREMENTS 15
 2.1 Scope 15
 2.2 Function and context of use 15
 2.3 Performance requirements 15

3 DESIGN FOR ACCESS AND MOBILITY 16
 3.1 Scope 16
 3.2 General 16
 3.3 Design 16
 3.4 Minimum dimensions 18
 3.5 Wheelchairs 18
 3.6 Symbol of access and symbol for deafness 18

4 ACCESSIBLE ROUTES 19
 4.1 Scope 19
 4.2 Accessible route 19
 4.3 General 19
 4.4 Kerb ramps 19
 4.5 Hazards and obstructions 19
 4.6 Surface Finishes 20
 4.7 Direction Indicators 21
 4.8 Signs 22
 4.9 Viewing ranges 23
 4.10 Visibility factors 24
 4.11 Controls and Fittings 27
 4.12 Alerting devices 27
 4.13 Audible and visual 27

5 CAR PARKS 28
 5.1 General 28
 5.2 Location 28
 5.3 Signs 28
 5.4 Number required 28
 5.5 Car park dimensions 29
 5.6 Surface 30
 5.7 Access from car park 30
 5.8 Shelter 31
 5.9 Facilities accessible from a vehicle 31
 5.10 Directory boards 31

NZS 4121:2001

6	FOOTPATHS, RAMPS AND LANDINGS	32
6.1	General	32
6.2	Footpaths	32
6.3	Moving walkways	33
6.4	Ramps	33
6.5	Landings for ramps	35
6.6	Fairing of surfaces	38
7	ENTRANCES, CORRIDORS, DOORWAYS AND DOORS	39
7.1	Entrances	39
7.2	Corridors	40
7.3	Doorways	40
8	STAIRS	44
8.1	General	44
8.2	Single steps	44
8.3	Stair design	44
8.4	Stair construction	46
8.5	Provision of auditory and visual cues	47
8.6	Handrails	47
9	LIFTS	49
9.1	General	49
9.2	Design	50
10	TOILET AND SHOWER FACILITIES	53
10.1	General	53
10.2	Location	53
10.3	Signs	53
10.4	Number of toilets and showers	53
10.5	Design	53
11	PUBLIC FACILITIES	62
11.1	Public counters and desks	62
11.2	Telephones	62
11.3	Automatic tellers, vending machines	64
12	PLACES OF ASSEMBLY, ENTERTAINMENT AND RECREATION ...	66
12.1	General	66
12.2	Places of assembly and entertainment	66
12.3	Places of recreation	67
13	ACCESSIBLE OUTDOOR PUBLIC AREAS	69
13.1	General	69
13.2	Outdoor hazards	69
13.3	Kerb design	71
13.4	Kerb ramps	72
13.5	Street furniture	76
14	ACCESSIBLE ACCOMMODATION	78
14.1	Scope	78
14.2	Application	78
14.3	General	78
14.4	Access	78
14.5	Accessible accommodation units	78
14.6	Arrival and departure	79
14.7	Accessible accommodation	79

APPENDIX

A	Statutory obligations relating to access and building	89
B	Performance requirements of the New Zealand Building Code relating to access and facilities for people with disabilities	94
C	Design for access and mobility – Alterations to buildings	102
D	People with disabilities: Mobility and mobility aid information	107
E	International symbols	117
F	Handrails and grab rails	119
G	Scissor stairs	121
H	Hearing augmentation – Listening systems	123

TABLE

1	Number of car parks	28
2	Number of accessible units	78
3	Number of toilets	86
C1	Clear width of doorway	103
D1	Average dimensions of motorized wheelchairs and scooters	110

FIGURE

1	Approachability, accessibility and usability	17
2	Height clearance on accessible routes	20
3	Examples of signs indicating a facility and its direction	23
4	Public parking sign	23
5	Zones for viewing and for common viewing	24
6	Stair visibility	26
7	Car parking	29
8	Vertical clearance	30
9	Facilities accessible from vehicle	31
10	Maximum allowable camber for footpaths and ramps	32
11	Zigzag ramps: layout	34
12	Safety on ramps	34
13	Footpath and ramp handrails	36
14	Landings to outward opening doors	37
15	Landings to inward opening doors	37
16	Section through a step ramp	38
17	Threshold ramp	39
18	Revolving door with side hung door	40
19	Space requirements in confined spaces	40
20	Clear width of doorway	41
21	Minimum glazing in doors	42
22	Good stair design	44
23	Pitchline and extension of handrails	45
24	Opening of doors	46
25	Basic profile of stairs	47
26	Lift car dimensions and control panel	51
27	Accessible toilet units	54
28	Grab rails and kick plates on toilet doors	55
29	Wall hung pans	56
30	Location and clearances for washbasins and fittings	57
31	Toilet unit fittings – positioning of grab rail and paper roll holder	58
32	Toilet unit fittings – zone for position of flushing control	59

NZS 4121:2001

33	Minimum space required for a single shower unit	59
34	Shower cubicle fittings	61
35	Combined toilet and shower	61
36	Public counters and desks	62
37	Public counters	63
38	International symbols for people with hearing impairment	64
39	Automatic teller or vending machine	64
40	Places of assembly – Examples of seating arrangements	67
41	Outdoor hazards	69
42	Protection from dangerous projections	70
43	Space required between bollards, etc.	71
44	Kerb and channel design	71
45	Location of kerb ramps or step ramps	72
46	Kerb ramps	73
47	Tactile ground surface indicators at kerb ramps	74
48	Road crossings	75
49	Example of position of street furniture	76
50	Typical park bench seating	77
51	Example of kitchen layout and dimensions	80
52	Oven with worktop to allow for set-down	82
53	Example of dining and lounge layout and dimensions	84
54	Example of bedroom layout and dimensions	85
C1	Doorway width for narrow corridors	104
C2	Toilet compartment in existing building	106
C3	Handrail adaptation	106
D1	Crutches	107
D2	Tripods	107
D3	White cane	108
D4	Guide dog or child	108
D5	Sighted guide	108
D6	Guide dog run	109
D7	Basic scooter profile	110
D8	Typical wheelchair dimensions	111
D9	Minimum clear floor space	112
D10	Clear widths	113
D11	Passing space for wheelchairs	113
D12	Distance between tables and chairs	114
D13	Maximum horizontal reach to objects on table or bench tops	114
D14	Forward reach from a wheelchair	115
D15	Side reach from a wheelchair	115
D16	Storage shelves and wardrobes	116
D17	Area of common reach for ambulant people with disabilities and wheelchair users	116
D18	Ambulant reach	116
E1	International symbol for access	117
E2	International symbol for deafness	118
F1	Handrails	119
F2	Size and spacing of a grab rail	120
G1	Scissor stair design	122

RELATED DOCUMENTS

Reference is made in this Standard to the following:

NEW ZEALAND STANDARDS

NZS 4223:----	Code of practice for glazing in buildings
Part 3:1999	Human impact safety requirements
NZS 4241:1999	Public toilets
NZS 4332:1997	Non-domestic passenger and goods lifts
NZS 4512:1997	Fire alarm systems in buildings
NZS 6703:1984	Code of practice for interior lighting design
NZS/AS 1428:----	Design for access and mobility
Part 4:1992	Tactile ground surface indicators for the orientation of people with vision impairment
NZMP 6004: 1999	Safer electrical installations in homes – For children, the elderly and people with disabilities

JOINT AUSTRALIAN/NEW ZEALAND STANDARDS

AS/NZS 1680:----	Interior lighting
Part 0:1998	Safe movement
Part 2.4:1997	Industrial tasks and processes
Part 2.5:1997	Hospital and medical tasks
AS/NZS 1730:1996	Washbasins
AS/NZS 2107:2000	Acoustics – Recommended design sound levels and reverberation times for building interiors
AS/NZS 3661:----	Slip resistance of pedestrian surfaces
Part 1:1993	Requirements
Part 2:1994	Guide to the reduction of slip hazards
AS/NZS 3856:----	Hoists and ramps for people with disabilities – Vehicle-mounted
Part 1:1998	Product requirements
AS/NZS 4586:1999	Slip resistance classification of new pedestrian surface materials

AUSTRALIAN STANDARDS

AS 1088:----	Hearing aids
Part 4:1987	Magnetic field strength in audio-frequency induction loops for hearing aid purposes
AS 1428:----	Design for access and mobility
Part 2:1992	Enhanced and additional requirements – Buildings and facilities
Part 3:1992	Requirements for children and adolescents with physical disabilities
Part 4:1992	Tactile ground surface indicators for the orientation of people with vision impairment
AS 1735:----	Lifts, escalators and moving walks
Part 6(Int):1996	Moving walks
AS 2107:1987	Acoustics – Recommended design sound levels and reverberation times for building interiors
AS 2890:----	Parking facilities
Part 1:1993	Off-street car parking

NZS 4121:2001

BRITISH STANDARDS

BS 5252:1976	Framework for colour co-ordination for building purposes
BS 5776:1996	Powered stairlifts
BS 6440:1999	Powered lifting platforms for use by disabled persons
BS EN 115:1995	Safety rules for the construction and installation of escalators and passenger conveyors
BS EN 1154:1997	Building hardware. Controlled door closing devices. Requirements and test methods

NEW ZEALAND ACTS AND REGULATIONS

Building Act 1991
Building Regulations 1992 (includes the Building Code)
Fire Safety (Evacuation of Buildings) Regulation 1992
Fire Service Act 1975
Human Rights Act 1993
Local Government Act 1974
Resource Management Act 1991

OTHER PUBLICATIONS

Land Transport Safety Authority – Road and traffic guidelines
RTS Guideline No. 14. 1997. Guidelines for installing pedestrian facilities for people with visual impairment.

The users of this Standard should ensure that their copies of the above-mentioned New Zealand Standards or of overseas Standards approved as suitable for use in New Zealand are the latest revisions or include the latest amendments. Such amendments are listed in the annual Standards New Zealand *Catalogue* which is supplemented by lists contained in the monthly magazine *Standards* issued free of charge to committee and subscribing members of Standards New Zealand.

REVIEW OF STANDARDS

Suggestions for improvement of this Standard will be welcomed. They should be sent to the Chief Executive, Standards New Zealand, Private Bag 2439, Wellington 6020.

FOREWORD

The Building Act 1991 integrated the requirements for access and facilities for people with disabilities, previously covered by the Disabled People Community Welfare Act 1975, into the general building law and the provision of these facilities is enforceable under this Act.

NZS 4121 is cited in subsection (3) of section 47A of the Building Act 1991, as providing a means of compliance with the Building Code.

The access requirement in the Building Act applies in effect to all new buildings and existing buildings, other than private residential buildings, when they are altered, or there is a change in use. The access requirement also applies to driveways, accessways and passages within and between complexes and developments and associated landscaping (if any) that are intended to be used for, or associated with, one or more of the buildings to which the access requirement applies.

The purpose of the Standard is to provide guidance for those who are responsible for making buildings and facilities accessible to and fully usable by people who have disabilities. This is to be done in accordance with the access requirement that reasonable and adequate provision is made for people with disabilities who may be expected to visit or work in buildings and to enter and carry out normal activities and processes in those buildings. It should be noted that this requirement is considered from the view of the user and not the building owner.

In practice a building must be designed to enable people with disabilities to use the building with the same convenience as those who do not have disabilities.

This Standard provides a universal basis for the necessary dimensions and space needed to ensure that the structure and layout of both public and private accommodation and their other elements, facilities and features are accessible to and usable by people with disabilities. The requirements for public and private accommodation can of course be usefully used in the design of private dwellings.

The Building Act 1991 recognizes that people with disabilities are part of the community, and that any barrier which prevents them from participating in the social and economic life of that community must be eliminated. Architectural barriers cause the most difficulty in respect of access, not only for people with disabilities, but also for many other people, particularly the very young and the elderly.

Public building types such as shopping malls, supermarkets, department stores and airline terminals have been made more accessible, not only in consideration of people with disabilities, but because better access for the public at large improves these buildings, and makes them more attractive and usable for a wider cross-section of the population. When a building design is carried out with access as a primary element of the brief, access is provided much more cost-effectively than if it is treated in a secondary manner or as an afterthought.

Accessibility not only means access for people with disabilities, but it also ensures efficiency, comfort and convenience for everyone else. It is a practical matter, and not an emotional issue. In this Standard an endeavour has been made to relate the design rules to the practical experience which has been gained in implementing the access provisions since they came into force in New Zealand in 1977. This Standard is not

NZS 4121:2001

the only means of complying with the statutory provisions relating to access, and because of the diversity of building types the Standard does not attempt to cover all circumstances. What amounts to “reasonable and adequate provision” in respect of access is a matter to be decided in the design of each particular building having regard to the need to assist and encourage people with disabilities to become socially and financially independent.

Above all there is the absolute requirement to enhance their human rights, which are now protected by the Human Rights Act 1993, which prohibits discrimination on the grounds of disability.

The New Zealand Health Survey 1992-93 by the Ministry of Health confirms the need for access and facilities (especially lifts designed for use by all users). This survey showed that a quarter of the entire adult population has a mobility limitation.

The design requirements in the concepts of approachability, accessibility and usability are meant to ensure that accessible facilities are melded into the design of a building as a whole (including landscaping) so that the occupants of the building happily use these facilities without being conscious of their underlying purpose.

It will be recognized that ‘accessible’ routes for people with disabilities extend far past those on the building sites and within buildings, see definition of the accessible route, 1.5.1. Local and central government are required, through the Local Government Act 1974, the Resource Management Act 1991 and the Human Rights Act 1993 to provide clear access along pavements and to provide road crossings etc. for people with disabilities to use. This consideration automatically extends to the siting of street furniture, bollards and the like and the siting and design of public transport bus or train stops etc.

Access for people with disabilities should not be seen as “special”, but as part of a safe and convenient environment for everyone.

People with disabilities, their families and companions form a growing segment of the travelling public on business or holidays. Some commercial tour operators now actively promote and organise holidays within New Zealand and overseas operators are continually seeking suitable accommodation for tourists with disabilities who travel alone or with a group.

Accessible hotel and motel rooms should be decorated and furnished to the same standard as the other rooms in the premises.

The principle in design is that “good design for people with disabilities is good design for everyone”. It certainly does not mean that hospital style rooms should be built or that all guestrooms be specially designed.

People with disabilities also travel unaccompanied so they should be able to “use” hotels and motels with the same convenience as the non-disabled traveller. Having to call for assistance to do simple tasks is embarrassing for both staff and guest. This standard does not spell out all the aspects and elements for the complete design of accessible accommodation and common sense must prevail.

NEW ZEALAND STANDARD

DESIGN FOR ACCESS AND MOBILITY – BUILDINGS AND ASSOCIATED FACILITIES

1 GENERAL

1.1 Scope

1.1.1

This Standard sets out requirements for the design of buildings, facilities within buildings, driveways, car parks, passages and any associated landscaping and accessways for use by people with disabilities as required by the Building Act 1991 and the Local Government Act 1974.

It is written to cater for the majority of access and usage needs of people with disabilities, however, everyone benefits from accessible buildings in a variety of ways.

1.1.2 Types of buildings

This Standard shall apply to, but shall not be limited to, buildings, and parts of buildings, (including driveways, accessways, car parks and passages within and between complexes and developments, and associated landscaping, if any) that are defined in the Building Act Section 47A(4), refer to Appendix A, A3.1.

The Standard covers access provisions for the following types of buildings, refer also to Appendix A.

- “(a) Land, sea, and air passenger transport terminals and facilities and interchanges, whether wholly on land or otherwise;
- “(b) Public toilets wherever situated;
- “(c) Banks;
- “(d) Childcare centres and kindergartens;
- “(e) Day-care centres and facilities;
- “(f) Commercial buildings and facilities for business and professional purposes, including computer centres;
- “(g) Central, regional, and local government offices and facilities;
- “(h) Courthouses;
- “(i) Police stations;
- “(j) Hotels, motels, hostels, halls of residence, holiday cabins, groups of pensioner flats, boarding-houses, guest houses, and other premises providing accommodation for the public;
- “(k) Hospitals, whether public or private, nursing homes, and old people’s homes;
- “(l) Medical and dental surgeries, and medical and paramedical and other primary health care centres;

- “(m) Educational institutions, including public and private primary, intermediate, and secondary schools, universities, polytechnics, and other tertiary institutions;
- “(n) Libraries, museums, art galleries, and other cultural institutions;
- “(o) Churches, chapels, and other places of public worship;
- “(p) Places of assembly, including auditoriums, theatres, cinemas, halls, sports stadiums, conference facilities, clubrooms, recreation centres, and swimming baths;
- “(q) Shops, shopping centres, and shopping malls;
- “(r) Restaurants, bars, cafeterias, and catering facilities;
- “(s) Showrooms and auction rooms;
- “(t) Public laundries;
- “(u) Petrol and service stations;
- “(v) Funeral parlours;
- “(w) Television and radio stations;
- “(x) Car parks, parking buildings, and parking facilities;
- “(y) Factories and industrial buildings where more than ten persons are employed;
- “(z) Other buildings, premises, or facilities to which the public are to be admitted, whether on payment or otherwise.”

1.1.3 Structure of standard

The Standard is divided into 14 sections plus appendices:

Section 1	General information
Section 2	Performance requirements
Sections 3 – 14	Design rules for access and mobility including: <ul style="list-style-type: none"> – Accessible outdoor public areas – Accessible accommodation
Appendices	

1.1.4 Children with disabilities

This Standard is primarily written for adult people with disabilities. Reference may be made from time to time to provisions for children. The design of buildings and facilities to accommodate children e.g. childcare centres is covered in AS 1428.3, which deals specifically with requirements for children and adolescents with physical disabilities.

1.2 Objective

The purpose of the Standard is to provide workable solutions, which meet and integrate the performance criteria for access and facilities of the New Zealand Building Code (NZBC) into the overall design of buildings to which these requirements relate. Some of the requirements of this standard may exceed some of the requirements currently given in the Building Code and Approved Documents, and is expected to complement the Building Code. This is to be done by applying the principles of approachability, accessibility and usability to the overall design of buildings to ensure that people with disabilities are able to enter and carry out normal activities and processes in buildings and parts of buildings. These principles are

to be applied to driveways, car parks and passageways within and between complexes and developments and associated landscaping, if any.

The purpose of the Standard is also to provide workable solutions for the creation of accessways in urban areas that facilitate the movement of people between buildings, along pavements and across roads and streets.

Section 47A(3) of the Building Act states that this Standard is a means of establishing compliance with the Building Code (which is the first Schedule to the Building Regulations 1992) in respect of the provision of access and facilities for people with disabilities.

1.3 Application

1.3.1 Users

The Standard is intended for use by people with disabilities, occupational therapists, government departments, architects, designers, drafters, building owners, builders, local authorities, town planners, building officials and people with day-to-day control over the arrangement of facilities on a building site or within a building.

1.4 Statutory provisions

1.4.1 Building Act 1991

The Building Act has a number of sections relating to access and facilities for people with disabilities in buildings. The relevant sections are 6(2)(e), 34(7), 38, 46 and 47A. These are discussed in Appendix A.

1.4.2 NZS 4121

Under section 47A (3) of the Building Act, NZS 4121:2001, being a standard specification that is in substitution for NZS 4121:1985, is deemed to be one of the documents establishing compliance with the New Zealand Building Code, refer to Appendix A, A3.1 (3).

1.4.3 Local Government Act 1974

The Local Government Act requires Councils to provide safe and easy passage for people with disabilities from kerb to kerb of any road.

1.4.4 Resource Management Act 1991

The Resource Management Act provides for the inclusion of any matter relating to the management of any actual or potential effects of any use, development or protection described in its schedules on the community or any group within the community including minorities, children and disabled people, refer to Appendix A, A5.

1.4.5 Regulations

1.4.5.1 New Zealand Building Code

The Building Code in the First Schedule to the Building Regulations 1992 sets out the objectives, functional and performance requirements for buildings. The requirements in respect of people with disabilities are to be found in the following clauses (refer also to Appendix B):

- Clause D1 Access Routes
- Clause D2 Mechanical Installations for Access
- Clause F8 Signs

C1.4

Appendix A is an informative Appendix entitled 'Statutory obligations relating to access and building' and outlines the obligations imposed on designers, building owners and territorial councils by New Zealand law that provides for people with disabilities.

C1.4.3

See section 331 of the Local Government Act, or refer to Appendix A, A4.1.

Clause G1	Personal Hygiene
Clause G2	Laundering
Clause G3	Food Preparation and Prevention of Contamination
Clause G5	Interior Environment
Clause G9	Electricity
Clause G12	Water Supplies

1.4.5.2 Fire Safety (Evacuation of Buildings) Regulation 1992

The Fire Safety (Evacuation of Buildings) Regulations require that access for people with disabilities shall not be denied on the grounds that there are problems with fire safety and evacuation from a building, refer to Appendix A, A6.

1.5 Definitions and interpretation

1.5.1 Definitions

For the purpose of this Standard the following definitions shall apply:

ACCESSIBLE means having features that permit use by people with disabilities.

ACCESSIBLE ROUTE means a route that is usable by people with disabilities. It shall be a continuous route that can be negotiated unaided by a wheelchair user, walking device or by a person with a guide dog. The route shall extend from the street boundary and car parking area to those spaces within the building required to be accessible to enable people with disabilities to carry out normal activities and processes within the building.

ACCESSIBLE STAIRWAY means a stairway having features for use by people with disabilities. Buildings required to be accessible shall have at least one accessible stairway leading off an accessible route whether or not a lift is provided.

ACCESSWAY means a continuous accessible path of travel to buildings and between buildings, along pavements or across roads or streets, which provides access to all the facilities. This may include footpaths, ramps, and stairs.

ALL-GENDER means no distinction or restriction on access or use made on the basis of gender.

BUILDING means 'Building' as defined by section 3 of the Building Act, refer Appendix A of this Standard.

CIRCULATION SPACE means the net unobstructed area for a minimum height of 2000 mm above the finished floor or ground surface (unless otherwise specified in this Standard), which is that space surrounding built elements, landscape elements, and fixtures and fittings required for movement into and within buildings.

CONSTANT CONTACT TECHNIQUE means a white cane technique in which the person with a visual impairment keeps the cane tip on the ground, and sweeps from side to side in front of them, using an arc to cover the body width.

COUNCIL means a territorial local authority within the meaning of the Local Government Act 1974.

CUE sometimes also referred to as clues. An element within the environment which can be felt, heard, seen or smelt, and which assists a person with visual impairment to establish their location or direction of

travel. Some important cues such as changes in angle of a floor surface are sensed within the body [proprioceptively] rather than at the extremities [touch].

- GOING
- of a step is the horizontal distance from the nosing of one tread to the nosing of the next tread;
 - of a stair is the total horizontal distance travelled of a stair;
 - of a ramp is the horizontal distance travelled of a ramp

GRAB RAIL means a rail used to steady, stabilize, or support the full weight of a person who is changing position.

GROSS FLOOR AREA means the superficial area on the plan of a floor of a building measured over its outside dimensions including walls.

HANDRAIL means a rail used in circulation areas such as corridors, passageways, ramps and stairways to assist in continuous movement.

INTERNATIONAL SYMBOL OF ACCESS (ISA) – Refer to Appendix E.

KERB means a side barrier to a trafficable surface.

KERB RAMP means a short ramp, length not greater than 1520 mm and a gradient not steeper than 1 in 8, cutting through a kerb or built up to the kerb.

LANDING means a flat or crowned surface with a gradient not steeper than 1 in 50, e.g. a rest area on a ramp, stairway or walkway.

LANDMARK means any cue that is easily recognizable and that has a known and exact location in the environment.

MAIN ENTRANCE means the principal entrance that is used as a matter of course by people visiting or working in the building.

MOBILITY means the act of movement within the physical environment.

NOSING means the rounded projecting edge to a stair tread.

ORIENTATION means the process involved in monitoring one's position in space, through the use of the senses and in relation to the known patterns of environment, to facilitate purposeful movement.

PEOPLE WITH DISABILITIES means people whose ability to be freely mobile or to access and use buildings is affected by mental, physical, hearing or sight impairment, such as:

- (a) An inability to walk;
- (b) Walking difficulties;
- (c) Reliance on walking aids;
- (d) Partial sightedness or total blindness;
- (e) Hearing disabilities;
- (f) Lack of co-ordination;
- (g) Reaching disabilities;
- (h) Manipulation disabilities;
- (i) Lack of stamina;
- (j) Difficulties in interpreting and reacting to sensory information;
- (k) Extremes of physical size;
- (l) Learning difficulties.

PEOPLE WITH VISUAL IMPAIRMENT includes: people who are totally blind [around 5 %], those who are blind but have some light perception, and people who have low vision whose sight may be affected in one or more of a wide variety of ways.

PLACES OF ASSEMBLY means in addition to theatre, cinema, or public hall, a building or part thereof used or intended to be used as a place of assembly for 250 or more people, seated or unseated.

RAMP means an inclined accessible route with a gradient steeper than 1 in 20 but not steeper than 1 in 12. 1 in 14 is preferred as many people have difficulty negotiating a steeper ramp.

SHORELINE means a continuous tactile cue that runs parallel to the desired direction of travel for a person with a visual impairment. For example a wall or edge of a grass perm bordering a footpath.

SLIP RESISTANT means a walking surface that has a coefficient of friction (Φ) under all conditions of normal use, of no less than $\Phi = 0.4 + 0.0125 S$, where S is the slope of the walking surface as a percentage.

SQUARING OFF the act of aligning and positioning one's body in relation to an object for the purpose of establishing a definite position and orientation in the environment and subsequently an accurate line of travel. Used commonly by people with a visual impairment prior to crossing open spaces.

STEP RAMP means a short ramp with a length not greater than 1520 mm and a gradient not steeper than 1 in 8, replacing a step or located in a step other than a kerb. Refer kerb ramp.

SUPPORT RAIL means a rail used to provide steadying or stabilizing assistance.

TOILET UNIT means a self contained fully enclosed space or room within a toilet facility containing a water closet or privy, a hand basin and possibly other toilet features.

TOUCH TECHNIQUE means a white cane technique in which the person with a visual impairment touches the cane on the ground where they will place their foot next.

WALKWAY means any accessway with a gradient not steeper than 1 in 20.

1.5.2 Interpretation

For the purposes of this Standard the word “shall” refers to practices that are mandatory for compliance with this Standard, while the word “should” refers to practices which are advised or recommended.

Clauses prefixed by “C” and printed in italic type are intended as comments on the corresponding mandatory clauses. They are not to be taken as the only or complete interpretation of the corresponding clause, nor should they be used for determining in any way the mandatory requirements of compliance within this Standard. The Standard can be complied with if the comment is ignored.

The terms “Normative” and “Informative” have been used in this Standard to define the application of the Appendix to which they apply. A “Normative” Appendix is an integral part of a Standard whereas an “Informative” Appendix is only for information and guidance. Informative provisions do not form part of the mandatory requirements of the Standard.

2 PERFORMANCE REQUIREMENTS

2.1 Scope

This section of the Standard identifies the requirements for access and facilities for people with disabilities.

2.2 Function and context of use

2.2.1 Function

The function of design specifically for people with disabilities is to provide suitable access and facilities to and within buildings for any type of disability.

2.2.2 Context of use

A disability may be temporary or permanent. A disability may affect mobility to the extent that a wheelchair is necessary, may affect use of the arms and hands or the flexibility or balance of the body, or it may affect sight or hearing partially or totally. At any one time at least 20 % of the population have some kind of disabling condition.

People with disabilities still have a need to visit or to work in buildings. The Building Code, through its objectives and functional and performance requirements, establishes access requirements and facilities within buildings which are intended for use by all people regardless of any degree of disability.

However, the building owner and designer still have to give special recognition in building design to the needs of people who have a disability. This Standard, based on a long practical experience, is produced to provide the designer with methods, techniques and solutions that will meet their needs.

Through section 47A of the Building Act this Standard is accepted as deemed to be one of the documents establishing compliance with the Building Code (NZBC). As such it is only one way of meeting the performance requirements of the NZBC. Designers may use 'alternative solutions' provided they can show the alternative meets the performance requirements.

2.3 Performance requirements

2.3.1 The Building Code (NZBC)

The performance requirements for design for access and mobility are those given in the relevant clauses of the NZBC noted in 1.4.5 and Appendix B of this Standard.

2.3.2 This Standard

Sections 3 to 14 of this Standard identify and use many 'criteria' that are based on current experience with current equipment, or on parameters such as an average person's size or reach. The Standard identifies minimum requirements, (particularly for dimensions), which will comply with the minimum performance requirements of the NZBC. However, it may also recommend more useful or best practice criteria, which would then be in excess of the minimum requirements of the NZBC.

2.3.3 Listening systems

The performance requirements for listening systems suitable for use in public places are to be found in Appendix H.

Hearing augmentation – listening systems shall be:

- (a) Usable by people who do not have hearing aids;
- (b) Suitable for a range of severity of hearing impairment;
- (c) Safe and easy to use/control;
- (d) Suitable for intended use;
- (e) Maintained regularly.

3 DESIGN FOR ACCESS AND MOBILITY

3.1 Scope

3.1.1 New buildings

This section of the Standard provides guidance for the design of new buildings and facilities to enable people with disabilities, to get to, enter and use a building or facility unaided.

The particular buildings and facilities or parts of buildings and facilities are those which section 47A of the Building Act refers, refer to 1.1.2 and Appendix A.

3.1.2 Alterations to existing buildings

Alterations to existing buildings can pose difficult design challenges for compliance with this Standard. In Appendix C design solutions for common alteration problems are suggested. These are acceptable only when there is no other way of bringing the building into compliance with the Building Code. These alternatives are allowed at a cost to people with disabilities and shall not be used in new building construction.

3.2 General

3.2.1 Approachability, accessibility and usability

Design shall be carried out by applying the principles of approachability, accessibility and usability to the overall design to ensure that people with disabilities, visitors and workers are able to enter and carry out normal activities and processes in buildings and parts of buildings. These principles which are illustrated in figure 1, are also applied to driveways, accessways and passages within and between complexes and developments and associated landscaping.

3.3 Design

3.3.1 Minimum provisions

In addition to the maximum requirements of this Standard, notes are given below to extra provisions necessary for certain types of building.

- (a) Transport terminals
Accessible routes shall serve all parts of a terminal. This access provision shall apply to floors above or below ground level, and shall include access to such facilities as cash machines, booking / ticketing, luggage delivery, restaurants, bars, cafes, canteens, shops, banks and post offices.
- (b) Educational institutions etc.
 - (i) Buildings. In educational institutions the teaching, social, recreational and administration buildings, used by both students and staff, shall be connected by an accessible route.
 - (ii) Libraries, laboratories, resource rooms and facilities providing for other similar specialist activity shall be located on an accessible route, except where they are duplicated and then at least one shall be on an accessible route.
 - (iii) Showers. Where showers are provided, at least one shower for each gender (or one all gender shower) shall be accessible in accordance with 10.5.11.

C3.1.2

Refer to Appendix A4.2 which covers section 38 of the Building Act, dealing with alterations to existing buildings.

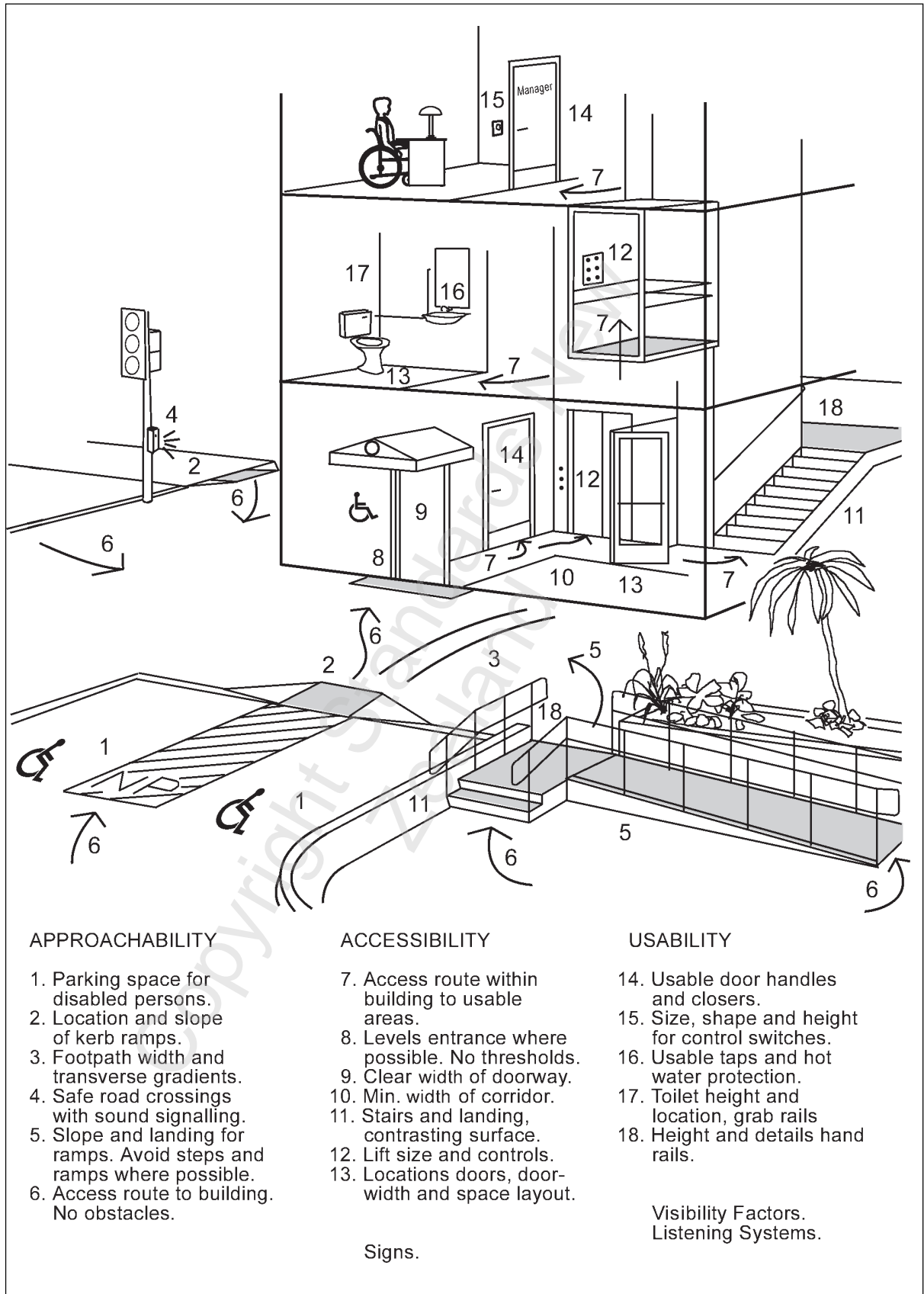

Figure 1 – Approachability, accessibility and usability

C3.4

Greater flexibility and ease of use of the space or facility is often achieved by increasing these dimensions, as well as extending the opportunities to design for greater comfort and convenience.

(iv) Toilets. In the case of primary schools the height of toilet pans and other facilities in toilet compartments may be varied from that shown in this Standard to meet the special needs of young people with disabilities.

(c) Industry

The provisions of this Standard are not required to be applied to factories unless the number of people employed is more than ten. Where the number of people employed is more than ten, accessible facilities shall be in accordance with this Standard.

3.3.2 Bilateral provision

Whenever possible, when two or more facilities are to be provided, the designer shall provide right and left-handed arrangements of fixtures and fittings.

3.4 Minimum dimensions

The floor space and door opening dimensions in this Standard are shown as minimum measurements.

The space requirements for people with disabilities using various aids, or with the support of another person are to be found in Appendix D.

3.5 Wheelchairs

The basic dimensions of currently used wheelchairs upon which this Standard is based and the space and reach requirements of the wheelchair user are to be found in Appendix D.

3.6 Symbol of access and symbol for deafness

Section 47A of the Building Act requires that the International Symbol of Access be displayed on buildings which are, or have been made accessible, refer to Appendix A, A3.1 (5).

It is essential that both the International Symbol of Access and the International Symbol for Deafness, see Appendix E, are displayed within accessible buildings to show the location of accessible facilities.

4 ACCESSIBLE ROUTES

4.1 Scope

This section covers a description of an accessible route and the features that are necessary for people with disabilities to effectively use the route.

4.2 Accessible route

4.2.1

An accessible route or routes shall be provided that connects from the point of arrival on site to those rooms and spaces required to be accessible to enable people with disabilities to visit and work and “carry out normal activities and processes” in the buildings and facilities, refer Appendix A, A3.

4.2.2

There will be situations where the local topography will not allow an accessible route requirement to be fully provided. Other solutions that provide reasonable and adequate access may be approved provided that the principles of accessibility are maximized in the alternative designs.

4.2.3

The accessible route includes paths, car parks, ramps, at least one public entrance, corridors, stairs, doorways and lifts within the building. For non-ambulatory people, the accessible route shall not incorporate any step, stairway, turnstile, revolving door, escalator or other impediment that would prevent it from being safely negotiated.

4.3 General

In order to achieve the objective of 4.1, people with disabilities shall be able to:

- (a) Park their cars in accessible car parks;
- (b) Approach the accessible main entrance (or entrances) to the building or facility by footpath on an accessible route;
- (c) Enter the building or facility at an entrance, which has a level threshold, or which is approached via an incline or ramp with an appropriate gradient;
- (d) Move freely inside and to use the facilities within the building or facility, except as provided for in this part of the Standard;
- (e) Operate electronic access mechanisms and systems.

4.4 Kerb ramps

Kerb ramps shall be provided and designed according to 13.4.

4.5 Hazards and obstructions

4.5.1 General

The accessible route shall have the required height and width clearance and shall be free from hazards and obstructions at all times.

C4.2

Accessible routes are not required to such places as plant rooms, pumping station shafts etc.

C4.5.3

People working in certain types of buildings such as supermarkets and other retail outlets, libraries, restaurants and cafes often erect or reorganize display stands or move furniture such that the accessible route is blocked or encroached upon.

C4.5.4.2

The provisions of the Fire Service Act apply.

C4.6.1

Factors which affect slip resistance are:

- (a) Approved Document D1/AS1 refers to AS/NZS 3661.1 and AS/NZS 3661.2. AS/NZS 3661.1 has been superseded by AS/NZS 4586;
- (b) Floor surfaces should be slip resistant when dry and should not be highly polished;
- (c) Paving bricks with bevelled edges or chamfered arises, and heavily textured and figured surfaces such as raked joint pavers are considered not traversable by a wheelchair;
- (d) Carpet and underlay need to be securely laid to prevent wave-like stretching. Carpet should be short-piled; i.e. not too long or soft, so as to impede wheelchair movement. Exposed junctions between carpet and other floor surfaces should be securely trimmed.

4.5.2 Height clearance

For accessible routes of unlimited length the height clearance shall be 2100 mm. For landings, stairways and corridors less than 2000 mm in length the height clearance shall be 2000 mm. These height clearances are illustrated in figure 2.

4.5.3 Clear route

An accessible route shall be designated as a clear route and maintained with a minimum width of 1200 mm, at all times, see 4.5.4.

4.5.4 Turnstiles and trolley traps**4.5.4.1 Access**

Whenever the accessible route into a building passes through turnstiles or trolley traps these shall allow unimpeded passage to a person with mobility aids including guide dogs.

4.5.4.2 Egress

The nominated 'means of escape' route shall be clearly indicated at the turnstile or trolley trap so that people with disabilities do not attempt to use the turnstile or trolley trap in an emergency.

4.5.5 Signs, lights and awnings

The requirements for hanging signs, lights and awnings and permanent and temporary obstructions are given in 13.2.

4.5.6 Projections

Minor, major and dangerous projections are covered by the requirements of Approved Document D1/AS1 of the NZBC.

4.6 Surface finishes

Ground, floor, ramp and stair tread surfaces shall be stable, firm and slip resistant under all normal environmental conditions.

4.6.1 Slip resistance

The requirements for slip resistance of accessible routes, ramps and stairs as specified in Approved Document D1/AS1 of the NZBC shall apply.

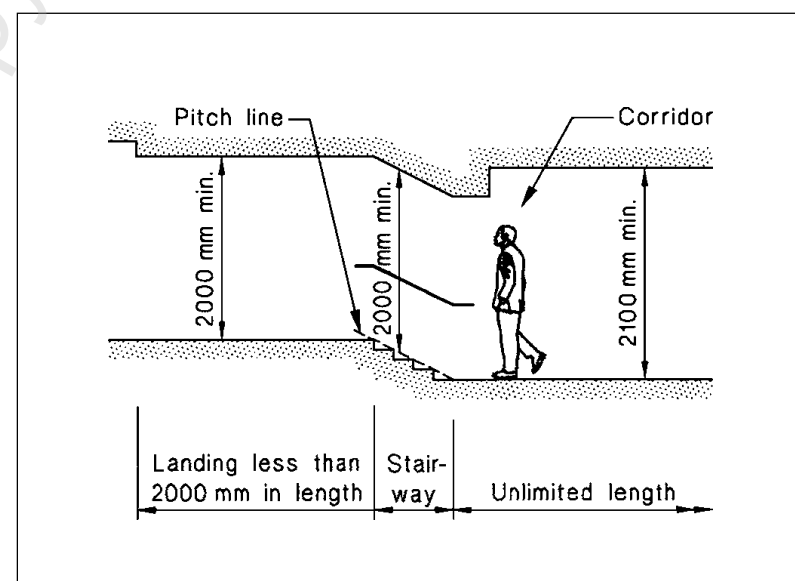

Figure 2 – Height clearance on accessible routes

4.7 Direction indicators

Direction indicators shall be installed on accessible routes in accordance with this Standard.

Most floor surfaces are reasonably slip-resistant when dry. All surfaces, except textiles, tend to become more slippery when they are on a slope, when they are wet or when they are covered with grit or mud. Particular attention should be given to floors in entrance lobbies, which can become slippery in wet weather.

The following finishes are some of those considered satisfactory, subject to the surface texture being traversable by wheelchair:

Dry locations:

- (a) All materials suitable for wet locations;*
- (b) Short-piled carpet i.e. having less than 6 mm pile height;*
- (c) Smooth flooring materials, which should not have a high-gloss, slippery finish, or which have been suitably treated to provide slip-resistance.*

Wet locations:

- (a) Concrete with abrasive or textured finish;*
- (b) Concrete with exposed aggregate finish;*
- (c) Bituminous concrete;*
- (d) Natural stone with rough finish;*
- (e) Paving bricks with special abrasive finish;*
- (f) Slip-resistant tiles;*
- (g) Profile decking timber;*
- (h) Broom finish concrete.*

C4.7

Direction indicators use a wide range of materials and principles, (sight, sound, touch). The most obvious indicator is the tactile tile set into the floor. Another tactile indicator is raised lettering or Braille. Changes in material in the accessible route e.g. from concrete to timber to rubber, produce different sounds and are good aural indicators. Designers should aim for reinforcement of cues and provide more than one cue.

C4.8.1

It is important for people who visit a building (and the staff who use it) to be aware of the facilities which have been provided for people with disabilities. The display of appropriate signs both inside and outside a building is important to increase a person's degree of independence and to avoid having to ask for directions. Signs are particularly helpful to people with hearing impairment.

C4.8.2.3

Signs positioned perpendicular to the path of travel are most likely to be noticed as many people with disabilities have limitations in the movement of their head, and reduced peripheral vision.

C4.8.2.4

The recommended fonts are Arial, Times New Roman or Helvetica Medium.

4.8 Signs**4.8.1 General**

Every building and support facility designed in accordance with this Standard shall have and maintain signs, both inside and outside the building.

4.8.2 Signs

Signs have three functions:

- (a) Informative – advising about availability of facility or service;
- (b) Directional – directing to specific facility;
- (c) Locational – identifying the place where the facility is provided.

4.8.2.1 Usage

Signs shall identify:

- (a) Accessible car parks;
- (b) Accessible entrances;
- (c) Services available in the building;
- (d) Accessible routes through buildings;
- (e) Accessible stairs or lifts;
- (f) Location of accessible toilet facilities;
- (g) Locations of rooms with listening systems.

4.8.2.2 Standard format

Signs shall indicate the direction and name or symbol of an accessible facility and shall incorporate the symbol of access in accordance with figure 3.

4.8.2.3 Position

Signs shall be positioned and located in a consistent manner. A sign shall be fixed on a wall at between 1400 mm and 1700 mm above floor level to lower edge of sign plate.

4.8.2.4 Lettering

The size, type and layout of lettering on signs shall be clear and legible.

4.8.2.5 Colour contrast

Lettering and symbols shall clearly contrast with the sign background.

4.8.3 International symbol of access

The proportional layout of the symbol of access shall be as shown in Appendix E.

4.8.4 Car parks

Figure 4 shows the preferred wording for signs in accessible parking areas and buildings.

4.9 Viewing ranges

The ultimate height zone for comfortable common viewing is shown in figure 5.

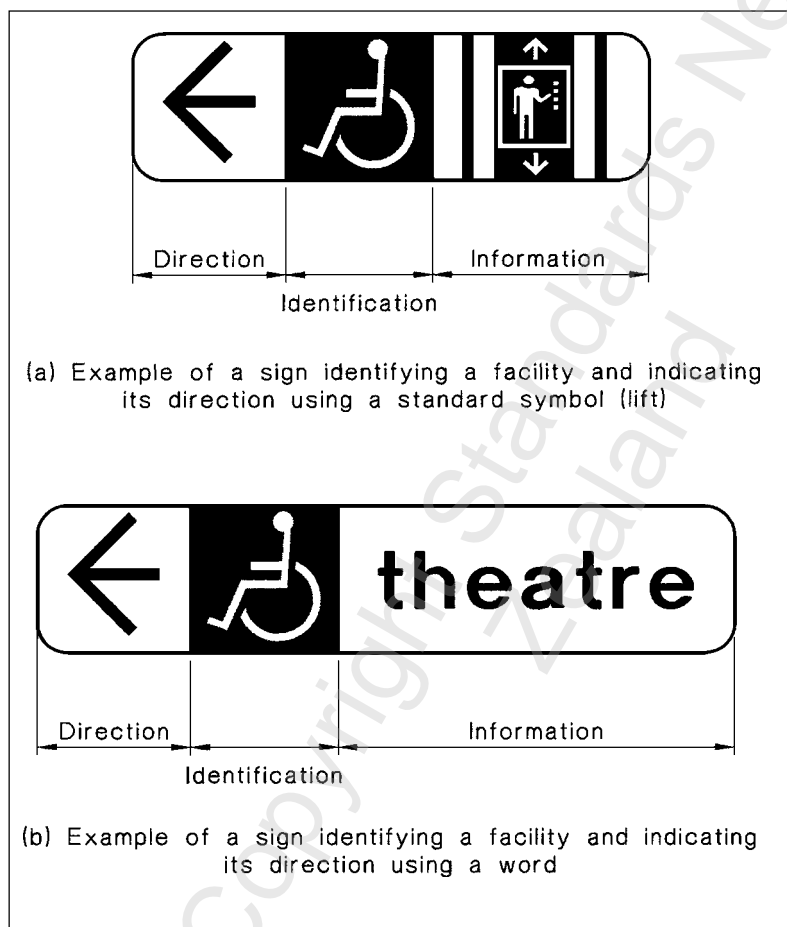

Figure 3 – Examples of signs indicating a facility and its direction



Figure 4 – Public parking sign

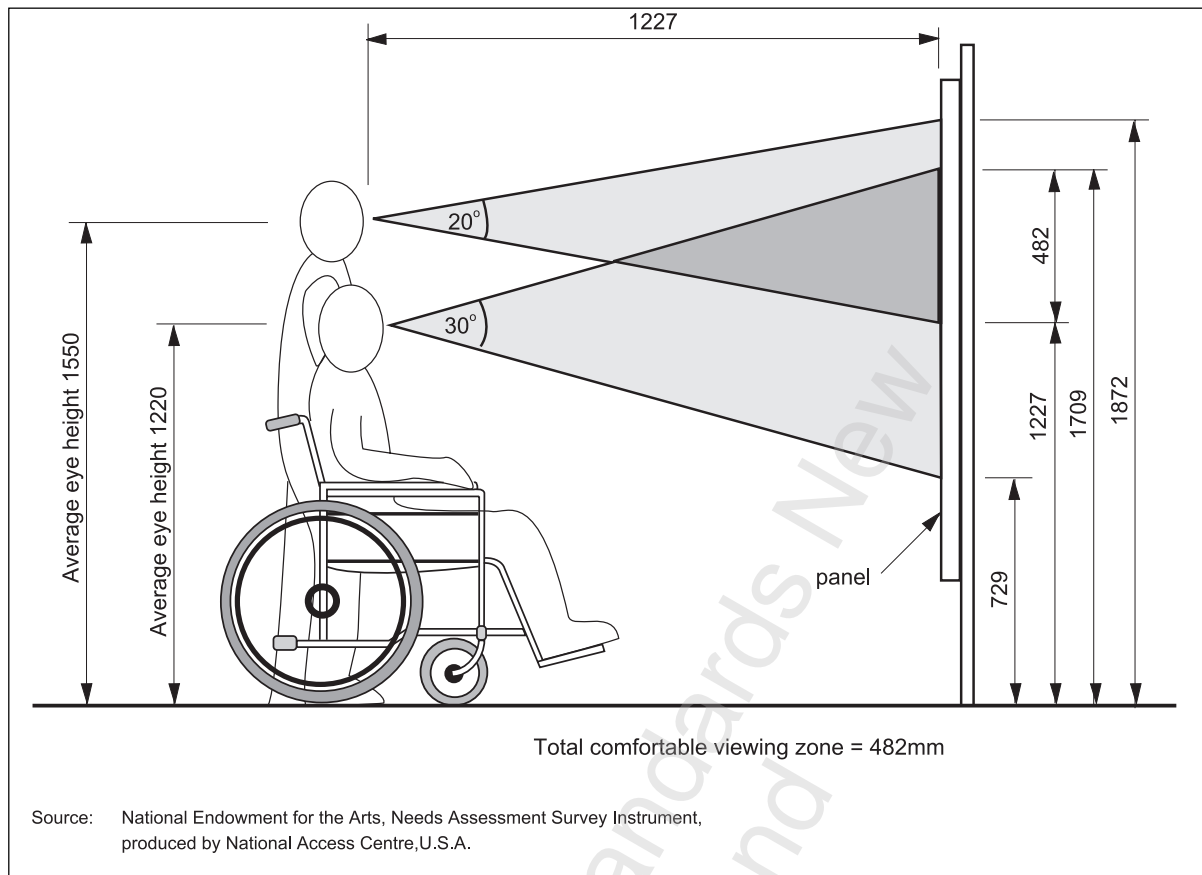

Figure 5 – Zones for viewing and for common viewing

C4.10.1

Factors that contribute to providing a good visual environment include:

- (a) Consideration of visual clutter to examine whether or not an object is distinct against the background;
- (b) Consideration of artificial and natural lighting options to investigate the absence of glare, accuracy of colour rendering and object modelling and the balance of illumination including graduated changes in levels of luminance through spaces;
- (c) Consideration of:
 - (i) Size of object to be identified
 - (ii) Sharpness of object form
 - (iii) Distance to object
 - (iv) Complexity of form
 - (v) Context in which an object is presented
 - (vi) Consistency of, or familiarity with the form of an object
 - (vii) Contrast of figure against the background
 - (viii) State of dark adaptation
 - (ix) Use of any visual aids.

4.10 Visibility factors

4.10.1 General

The visual environment shall be designed so as to maximize the usefulness of whatever level of vision a user may have.

4.10.2 Contrast

Where colour or texture changes are introduced they shall be made at corners, where there is a break in plane, at the junction of a stair tread and riser, or where a ramped surface meets a level surface.

4.10.3 Illumination levels

All illumination levels shall be not less than recommended in Appendix B of NZS 6703.

Illumination provisions shall highlight doors, signs, counters, stairs (top, bottom and treads) and other artificially lit areas.

C4.10.2

Colour change may be actual, or may be apparent e.g. by forming a permanent shadow. Variations in acoustic characteristics, lighting and wall and floor textures provide good cues about the environment for people who are blind or partially sighted.

Well-lit surroundings can mean the difference for someone who is partially sighted, of being independent or dependent. Glare from lights detracts from well-lit surroundings and the ability for those with loss of vision to navigate independently.

For people who are blind, variations in wall and floor textures can serve the same purpose.

C4.10.3

The illumination levels and requirements of NZS 6703 have been superseded in part by: AS/NZS 1680.0, which covers the general principles of safe movement in public areas of buildings; and AS/NZS 1690.2.4 and AS/NZS 1680.2.5, which give recommendations for the lighting levels necessary in industrial tasks and processes and hospitals and medical tasks respectively.

NZS 6703 should still be referred to for recommended lighting levels for circulation areas, entrances to buildings, car parks, offices and shops, public and educational buildings, homes and hotels.

Many people with disabilities require better lighting than is normally provided. This applies particularly to the elderly and those with impaired sight.

Lighting designers should avoid glare and sudden sharp changes in lighting levels. Diffused type lighting is preferred.

The use of natural light should be maximized where possible.

C4.10.4.1

People with a visual impairment need to be able to: locate the door in the wall line and find the fittings on the door. Contrast is needed between the elements as doors are sometimes left partially open. [Dark blue with dark red is not effective for example, despite being a contrast in colour].

Glass doors set in a largely glassed wall and wooden panelled doors set in a similarly panelled wall are difficult to locate. Door handles and associated furniture should contrast with the door.

C4.10.5.1

This may be achieved through:

- (a) Making the nosing of clear contrast colour with the rest of the stair;
- (b) Using different colours on the risers and the treads.

C4.10.5.2

These cues should be consistently used throughout a building. (For more information on visual cues, refer to 8.5).

4.10.4 Doors

Also refer to 7.3.

4.10.4.1 Door visibility

Contrast in lightness – darkness of colour shall be achieved between:

- (a) The door furniture (handles, keyhole plates etc.) and the door itself;
- (b) Either the door architrave frame and the wall or the door and the wall;
- (c) The door and the floor.

4.10.5 Steps and Stairs**4.10.5.1 Steps**

There shall be a clear contrast between the tread and the rise of all steps, which form a flight of stairs (see figure 6).

4.10.5.2 Stair visibility

The top and bottom of stairs shall be indicated by visual contrast supported by tactile and auditory warning cues.

4.10.6 Visual contrast of services

Handrails, lifts, switches and sockets and other services shall contrast visually to their background.

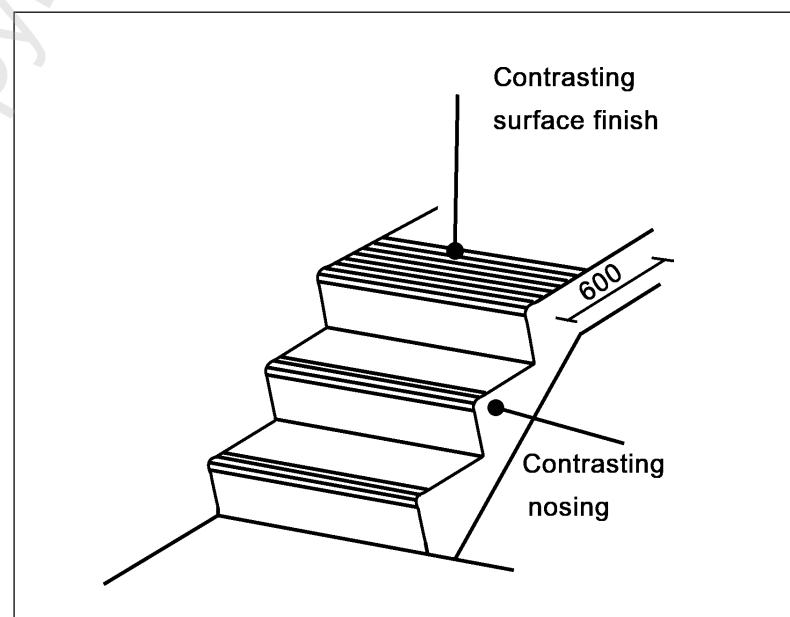

Figure 6 – Stair visibility

4.11 Controls and fittings

4.11.1 General

Controls and operating mechanisms installed along accessible routes and in usable spaces shall comply with the following clauses.

4.11.2 Door operation

Doors shall be able to be opened with one hand.

4.11.3 Window controls

Locking and opening controls to windows shall be between 900 mm and 1200 mm above the finished floor level.

Handles operating locks and latches shall have a lever action and the end of the handle shall be returned towards the window.

4.11.4 Electrical switches and socket outlets

Switches for electric light and power shall comply with the following requirements:

- (a) All light switches shall be horizontally aligned with door handles at 900 – 1200 mm optimum above finished floor level;
- (b) The toggle, rocker, push pad, or push button control of light switches shall project clear of the switch plate;
- (c) Socket outlets shall be fixed between 500 mm and 1200 mm above the finished floor level and at least 500 mm from corners and within a 500 mm horizontal dimension from the front of any bench or fixed unit.

4.11.5 Electronic access

Electronic access units for swipe-cards, key pads, door activating buttons etc. shall:

- (a) Have a level area with a stable, firm, slip resistant surface, 1200 mm x 1200 mm immediately adjacent to the access unit;
- (b) Be installed at 900 – 1200 mm, 1000 mm optimum, above the finished floor level;
- (c) Be installed no less than 500 mm from an internal corner;
- (d) Be installed adjacent to the door under control;
- (e) Have sufficient time-delay for the door to be opened before the locking system re-activates.

4.12 Alerting devices

Fire alarm systems shall have an audible and visual alerting device.

4.13 Audible and visual

The audible and visual aspects of the alerting device shall comply with the requirements of NZS 4512.

C4.11.2

Many door-closers are too strong for people with disabilities to operate, especially those in a wheelchair. It becomes impossible to open or to keep the door open. (Refer to 7.3.5 for forces required.)

All doors opening into a circulation space should have rising butt hinges or equivalent very low weight spring closures, as partially open doors represent a hazard to people who are blind or who have a visual impairment.

C4.11.3

The recommended height for the window control is 1000 mm.

C4.11.4

The recommended width of any push pad or button is 20 mm.

5 CAR PARKS

5.1 General

Section 47A of the Building Act covers the need to provide car parks, parking buildings and parking facilities, see Appendix A. Parking facilities or premises, whether private or public shall provide the required number of accessible car park spaces, refer to 5.4.

5.2 Location

5.2.1 Building owner provision

Parking spaces for people with disabilities shall be on the accessible route to a building and shall be provided close as practicable to the accessible entrance or to an accessible lift to the building or facility (see figure 1).

5.2.2 Council provision

Where car parking is provided by the local authority and not by the building owner then the required spaces shall be in the vicinity of the site or building and shall be connected to the site or building by an accessible route.

5.3 Signs

5.3.1

A sign incorporating the international symbol of access in accordance with 4.8, shall identify car park spaces. The sign shall be readily visible from a vehicle at the entrance to the car park, or guide signs shall be provided to indicate the direction of the space. The space shall have ground marking of the ISA, and may have additional signage.

5.3.2

Where an accessible main entrance to a building is not clearly visible from a street or parking area, directional signs of access shall be provided additional to any other necessary signs (see figure 1).

5.4 Number required

Where car parking is provided, spaces for people with a disability shall be provided in accordance with the following table:

Table 1 – Number of car parks

Total number of car parks	Number of accessible car park spaces
1 – 20	Not less than 1
21 – 50	Not less than 2
For every additional 50 car parks or part of a car park	Not less than 1

C5.4

Specific building types such as medical centres, entertainment centres and large retail facilities should provide greater numbers of accessible car parks than the minimum required.

5.5 Car park dimensions

5.5.1 Width

5.5.1.1 90° parking

Car park spaces set at 90° to the footpath shall be not less than 3500 mm wide (see figure 7).

5.5.1.2 Angle parking

Angle parks shall have an operational width of 3500 mm.

5.5.1.3 Parallel parking

Where the car park space is parallel and adjacent to a marked footpath on the same level as the parking space, the width of the common footpath may form part of the parking.

C5.5.1.1

The width of 3500 mm allows for the car and wheelchair to be on the same level when a person is transferring from one to the other.

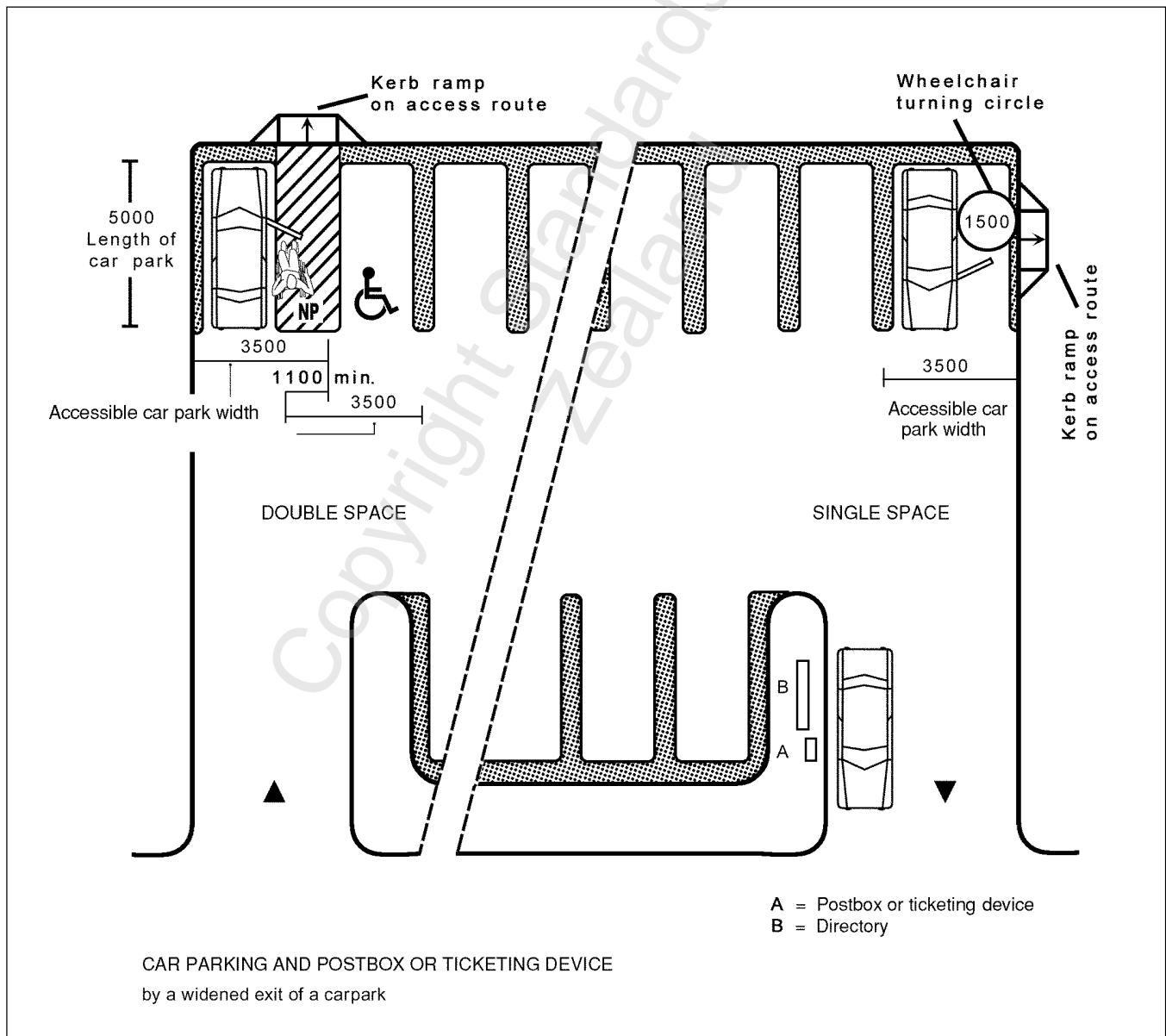

Figure 7 – Car parking

C5.5.3

When a wheelchair hoist is used, although the wheelchair is stored on the roof in a flat position, it is raised to the full height of the wheelchair plus the height of the roof rack during the hoisting process.

C5.7.4

Driveways may double as ramps and the design should exploit the full potential of driveways and parking areas.

Good transitions are required for the safety of those with visual and mobility impairments. For wheelchair users it is important to ensure that any curvature and cross-fall on foot paths or ramps do not cause one wheel of the wheelchair to leave the ground thus causing loss of control by the user, refer to 6.1(b).

5.5.2 Length

The design parking space length shall be at least 5000 mm (refer to AS 2890.1). For vehicles that operate a rear-mounted hoist a further 1000 – 1300 mm is required, refer AS/NZS 3856.1.

5.5.3 Headroom in parking buildings

There shall be a vertical clearance of not less than 2500 mm along accessible routes in car park buildings and above car park spaces for people with disabilities. At the parking space this headroom shall extend from the entrance to the space to a distance of not less than 2160 mm from the front of the space (see figure 8).

5.6 Surface

The accessible car park shall provide a stable, firm, slip resistant flat surface with a slope not exceeding 1:50.

5.7 Access from car park**5.7.1**

There shall be an accessible route from car parking areas.

5.7.2

People with disabilities shall not have to pass behind parked cars when moving to an accessible route or when approaching an entrance.

5.7.3

Flat access shall be provided whenever possible between the car park space and the adjoining footpath. A kerb ramp shall be provided (refer to 13.4) if there is any change in level from the parking space to the footpath.

5.7.4

Whenever footpaths join other footpaths, ramps, driveways, or parking areas, the transition shall be effected without abrupt changes in level or transverse gradient (also refer to 6.6).

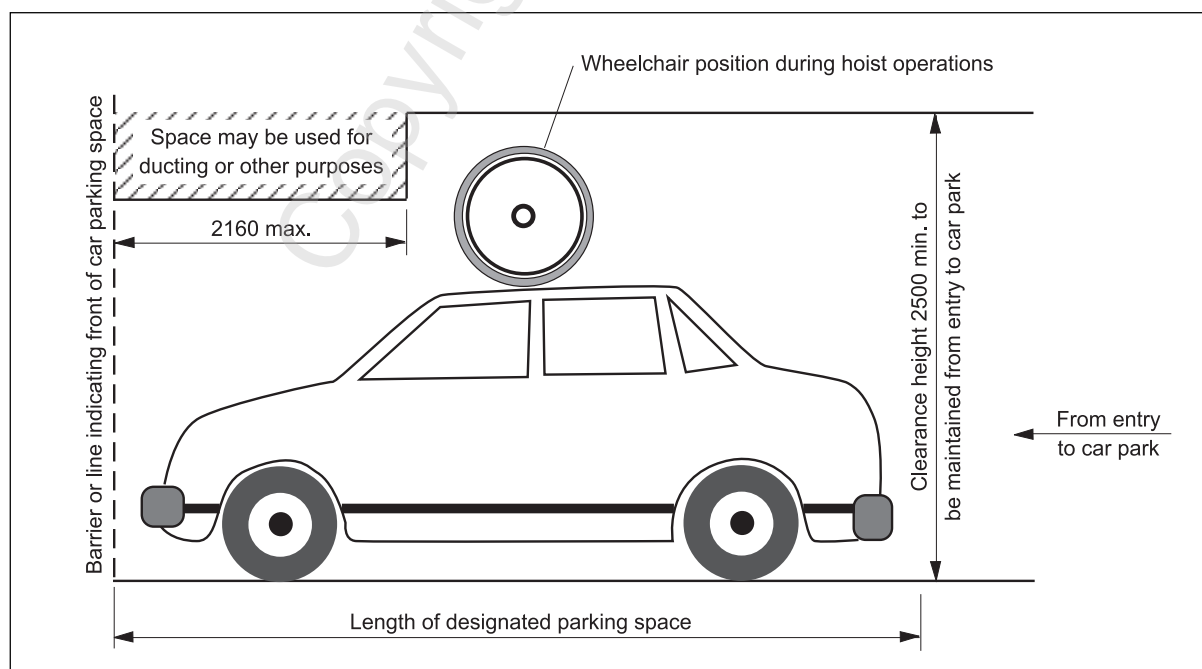

Figure 8 – Vertical clearance

5.8 Shelter

Car parks, drop-off points and accessible routes shall be covered whenever practicable.

5.9 Facilities accessible from a vehicle

The siting and elevation of post boxes, ticket dispensers and other kerb-side machines or facilities intended to be used by people who drive shall comply with figure 9.

5.10 Directory boards

Directory boards sited less than 1000 mm from the kerb shall be raked at least 6° from the vertical and be no higher than 1750 mm above ground level.

C5.8

People with disabilities can take a considerable time to transfer from a vehicle and to negotiate the accessible route to the building or facility. Covered car parks or drop-off points with space for two vehicles should be provided.

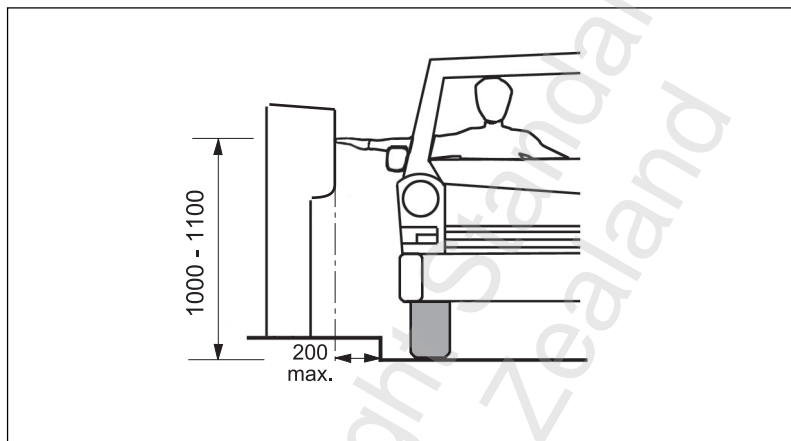

Figure 9 – Facilities accessible from vehicle

C6.1(b)

The transverse gradient or cross-fall of a footpath pulls the wheelchair to one side. A flatter surface also reduces the inclination of people who are blind or partially sighted to veer. Therefore wherever possible the transverse gradient should be flatter than the minimum requirements of this Standard.

6 FOOTPATHS, RAMPS AND LANDINGS**6.1 General**

The design and construction of footpaths and ramps on accessible routes shall comply with the following requirements:

- (a) The minimum clear width shall be 1200 mm at kerb level;
- (b) The transverse gradient of crowned or banked footpaths or ramps shall not exceed 1 in 50 (see figure 10).
- (c) Openings between bollards and similar barriers to non-pedestrian traffic shall be positioned or constructed to allow for the passage of wheelchairs or guide dog users and should visually contrast against the background for pedestrians with visual impairment (also refer to 13.2.5 and figure 43);
- (d) Landings shall be provided on footpaths and ramps in accordance with this Standard;
- (e) When a footpath, ramp or landing is situated so that a person could fall 1 m or more then a barrier shall be provided that meets the requirements of NZBC Clause F4/AS1. This requires the barrier to be 900 mm above ramps and 1000 mm above footpaths and landings;
- (f) The surfaces of footpaths, ramps and landings on accessible routes shall be slip-resistant with a texture that is usable by all people with disabilities (also refer to 4.6). Loose gravel or clay surfaces are not acceptable;
- (g) Where pavers are used as surfacing they shall have a flat upper surface, (unless being used as a tactile indicator surface), and shall be laid butted on a firm base

6.2 Footpaths**6.2.1 Ground surface level**

The natural ground surface adjacent to a footpath on an accessible route shall be as nearly flush with the finished surface of the footpath as possible, unless an upstand or barrier rail is provided.

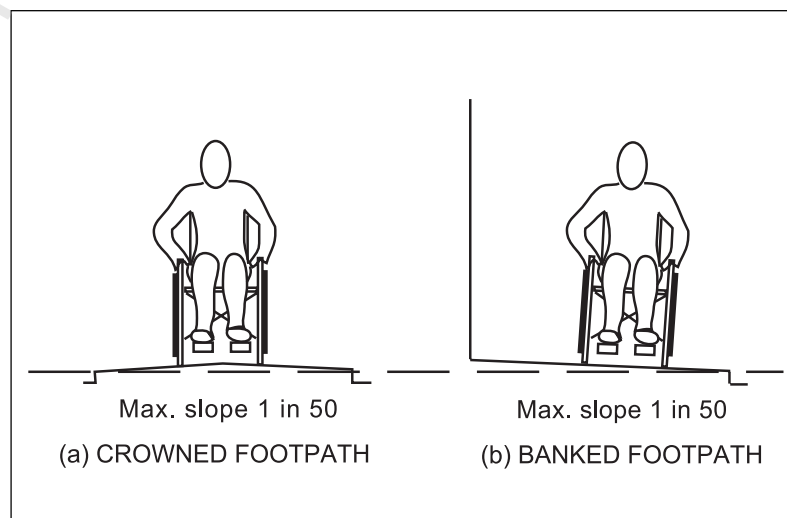

Figure 10 – Maximum allowable camber for footpaths and ramps

6.2.2 Gradient

Where the longitudinal gradient of a footpath is steeper than 1 in 33 but does not exceed 1 in 20 (also refer to 6.2.3), then level rest areas (also refer to 6.5) shall be provided at intervals not exceeding 18 m. These shall be not less than 1200 mm in length.

6.2.3 Footpaths as ramps

Where the longitudinal gradient is steeper than 1 in 20, the access shall be treated as a ramp, refer to 6.4.

6.3 Moving walkways**6.3.1 General**

Accessible moving walkways shall comply with the requirements of NZBC D2/AS3. The principal design factors are shown below.

6.3.2 Gradient

The accessible moving walkway shall have a maximum gradient of 1 in 10 (5.7°). Where an accessible moving walkway is provided an alternative means shall also be available (e.g. lifts and steps).

6.3.3 Speed

The rated speed of the moving walkway shall not exceed 0.75 m/s.

6.3.4 Width

The pallet or tread width shall be not less than 900 mm or greater than 1200 mm.

6.3.5 Handrails

A moving walkway shall be provided with handrails on both sides, which must move at the same speed as the walkway.

6.3.6 Encroachment

The moving walkway shall be extended into lower and upper landings by at least 1200 mm, with the handrails being extended a further 300 mm minimum.

6.3.7 Rest areas and landings

Rest areas or landings are not required on moving walkways.

6.4 Ramps**6.4.1 General**

Ramps can be straight, zigzag or L-shaped. Curved or circular ramps should not be considered as part of an accessible route.

When designing a building the following principles shall be considered:

- (a) Ramps should be avoided where it is possible to plan a building with level access;
- (b) Portable ramps are not an alternative to permanent ramps;
- (c) Where possible blend in with the design of the building or associated landscape.

C6.3.1

NZBC D2/AS3 uses BS EN 115 as its base reference document.

C6.3.2

Because a moving walkway assists wheelchair users by providing the motive power, the maximum gradient must not exceed 1:10. A gradient of 1:14 is recommended.

C6.4.1

Where there is a chance to provide a ramp less steep than specified in this Standard, this option should be taken. If a curved or circular ramp is provided it needs to adequately address the relationships of gradient, radius and width.

C6.4.2.1

Where there is space, associated landscaping can be designed to incorporate a path with a slight slope to avoid constructing a ramp to overcome a difference between the surrounding ground level and the floor level.

C6.4.2.2

Every effort should be made to construct a ramp as flat as possible. A maximum gradient of 1 in 14 should be used wherever it is achievable.

6.4.2 Design

6.4.2.1 Approachability

The approach to a ramp shall be level and allow for adequate visibility and wheelchair turning space.

6.4.2.2 Gradient

The maximum gradient of a ramp other than a kerb or step ramp shall be 1 in 12, figure 11.

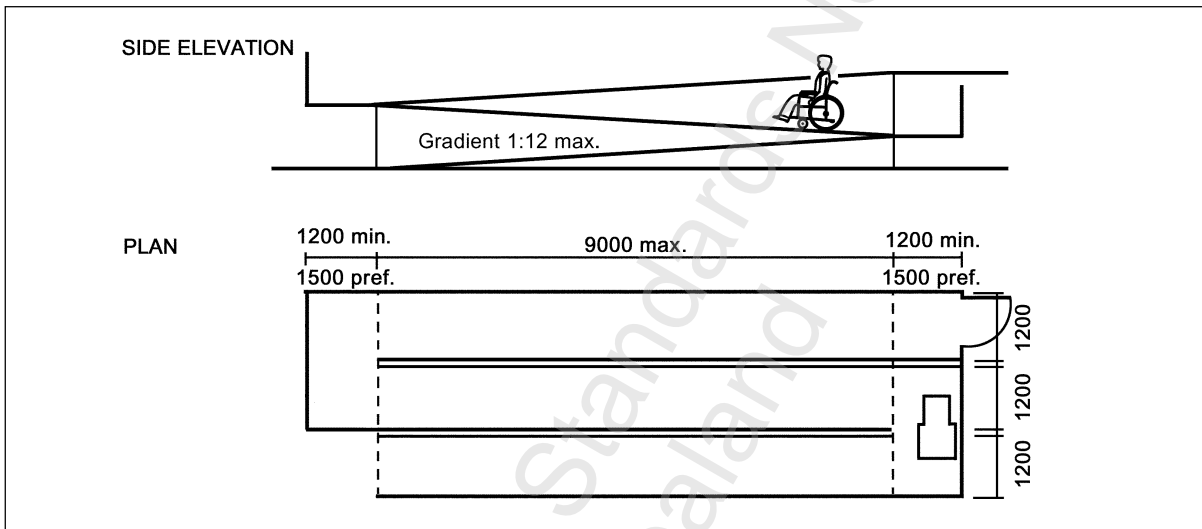
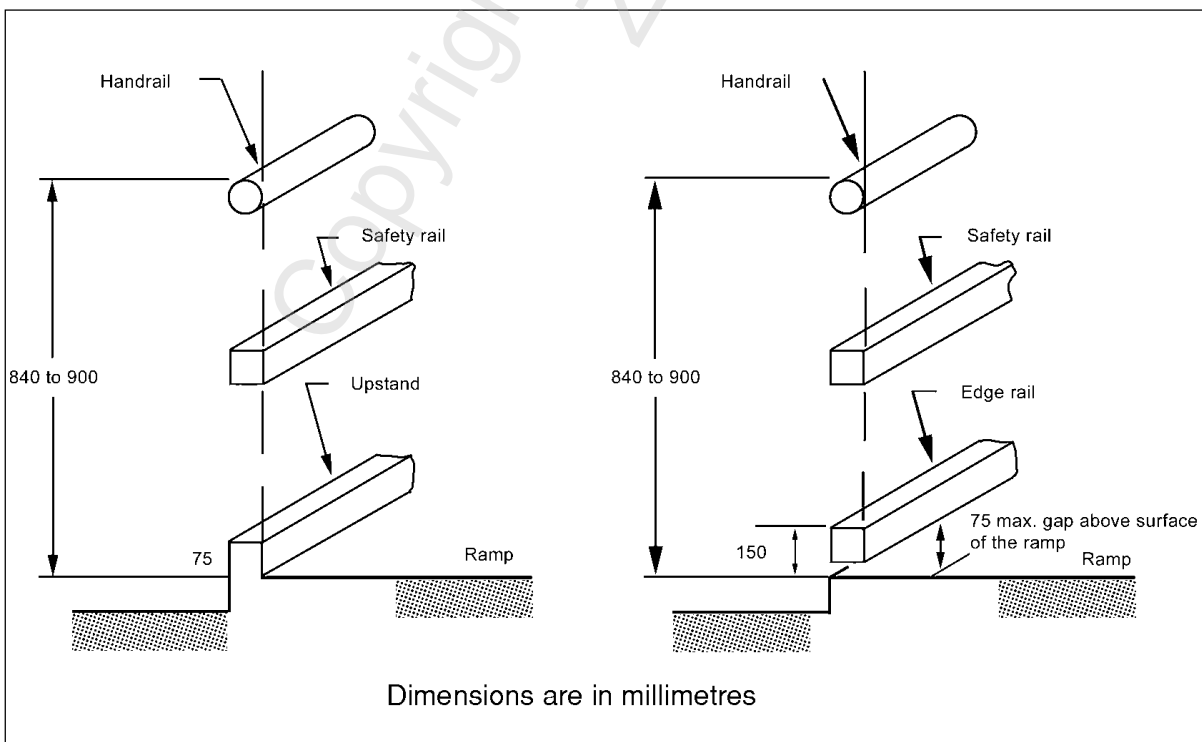

Figure 11 – Zigzag ramps: layout



Dimensions are in millimetres

Figure 12 – Safety on ramps

6.4.2.3 Gradient transition

Transitions from one gradient to another, as at the foot and head of ramps, shall be signalled by visual, textural and ideally, acoustic contrast.

6.4.2.4 Width

The tread width of a ramp shall be not less than 1200 mm.

6.4.2.5 Ramp edge safety

Ramps with a drop-off on one side shall have an effective method of control to prevent wheelchair wheels running off the ramp. Upstands or edge rails as defined below may be used (see figure 12). In addition there shall be a safety rail to prevent a person with disabilities from falling under the handrail.

6.4.2.5.1 Upstand

A ramp upstand shall be not less than 75 mm in height.

6.4.2.5.2 Edge-rail

The underside of an edge rail shall be placed no more than 75 mm above the ramp.

6.4.2.5.3 Safety rail

A safety rail shall be provided mid-height between the upstand or edge rail and the handrail (see figure 12).

6.4.2.6 Handrails

Ramps (excluding kerb and step ramps) shall have handrails at a height of 840 – 900 mm on both sides of the ramp and as shown in figure 13, refer to Appendix F for handrail design and 8.6.2.2 for visual contrast requirements.

6.5 Landings for ramps**6.5.1 General**

Ramps require level platforms or landings at the top and bottom, wherever there is a change in direction, wherever doors open off them and at intervals not exceeding 9000 mm (see figure 11), for ramp layout suggestions.

6.5.2 Size

Landings shall have a minimum dimension of 1200 mm.

6.5.3 Landing safety

Landings shall have handrails at a height of 840 – 900 mm on all open sides as shown in figure 12, (refer to Appendix F for handrail design).

C6.4.2.3

Auditory cues may be achieved through use of changes in material, e.g. suspended timber to concrete.

C6.4.2.5.2

The edge-rail may be of similar material and design to the hand and safety rails, or may be of other materials and designs that will stop a wheelchair when moving against it.

C6.4.2.6

Where people could fall 1000 mm or more from a ramp, a barrier at a height of 900 mm is required, refer NZBC clause F4/AS1.

C6.5.2

The example given in figure 11, of a zigzag ramp shows the option of a 1500 mm landing. This option allows the wheelchair user to rotate the wheelchair through 360°, enabling the landing to be used not only as a rest area, but also to return down the ramp.

Where possible a larger rest area, of 1500 mm in length, should be provided.

C6.5.3

Where people could fall 1000 mm or more from a landing, a barrier at a height of 900 mm is required, refer NZBC clause F4/AS1.

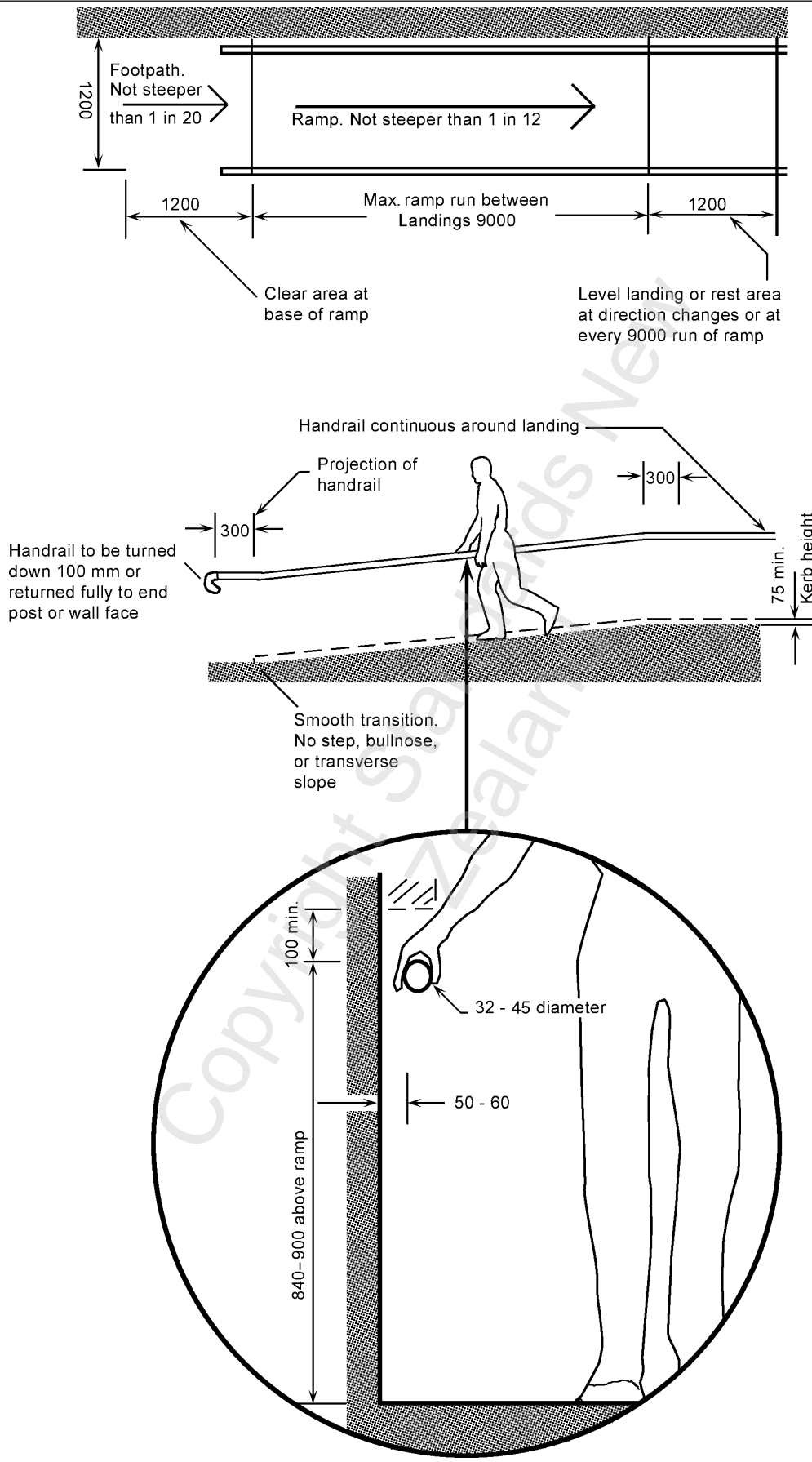

Figure 13 – Footpath and ramp handrails

6.5.4 Doorways

Landings or level rest areas that are provided in accordance with 6.5.1 shall also make allowance for the opening of doors as follows:

- (a) Where the door opens towards the ramp, a level rest area shall be provided in accordance with figure 14;
- (b) Where the door opens away from the ramp, a level rest area shall be provided in accordance with figure 15.

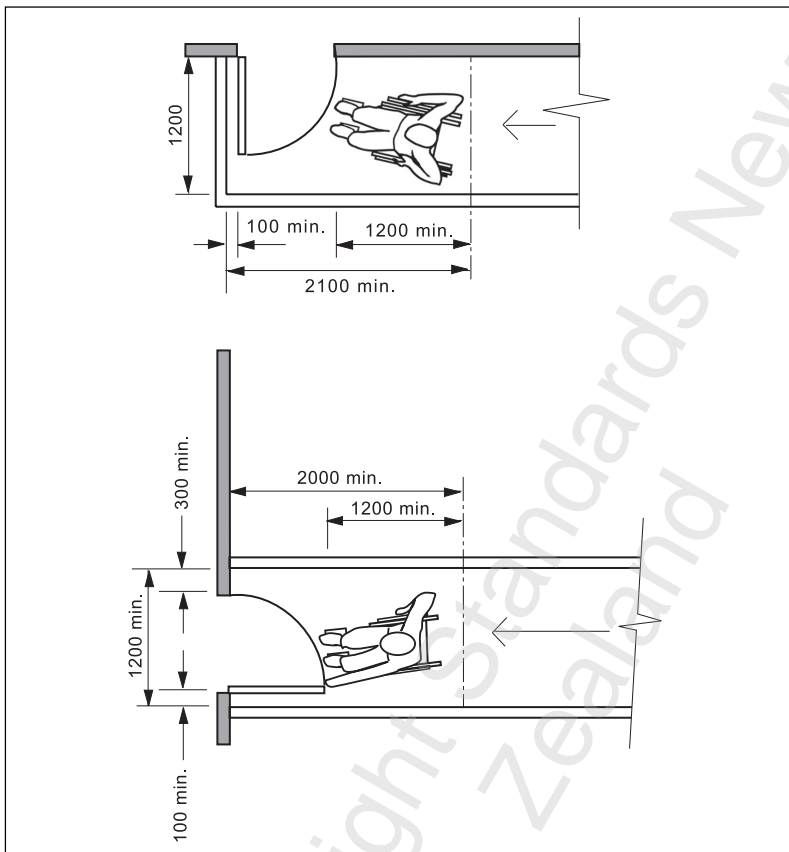

Figure 14 – Landings to outward opening doors

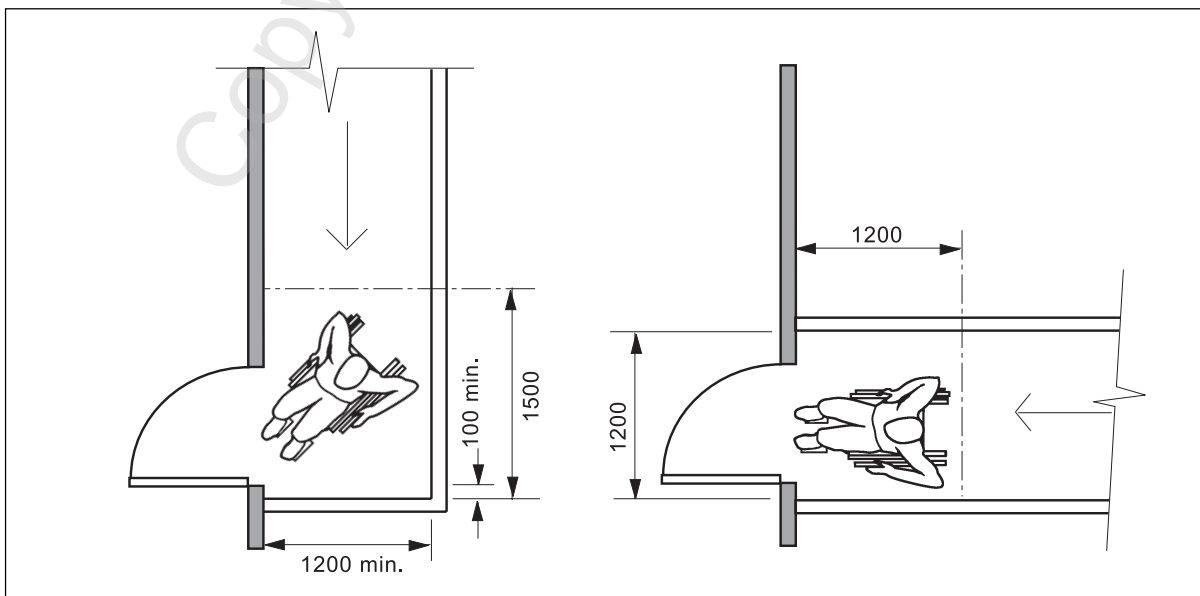

Figure 15 – Landings to inward opening doors

7 ENTRANCES, CORRIDORS, DOORWAYS AND DOORS

7.1 Entrances

7.1.1 General

Direct access shall be provided to the main entrance of a building, or to the internal space served by the main entrance via the accessible route.

7.1.2 Signs

All accessible entrances to a building shall be identified with appropriate signs posted, only if they are other than the main or principal entrance.

7.1.3 Design

An accessible entrance to a building or premises shall have a level threshold or an approach via an incline or ramp with an appropriate gradient.

The design of a main entrance to a building shall provide for:

- A level approach space no less than 1200 mm x 1200 mm both inside and outside the entrance door (see figures 14 and 15);
- An entrance way that is illuminated so as to be clearly distinguishable from the surroundings;
- Any automatic door-opening device to remain open for at least five seconds, or as long as it takes to clear the door whichever is the longer. It shall have a strongly contrasting visual strip device on the moving edge(s);
- Any automatic door opening device to be activated by people approaching from shallow angles;

Some people who are blind or partially sighted may use the building face as a trail to the door.
- Elimination of thresholds whenever possible.

7.1.4 Thresholds

Accessible entrances to a building or premises or to rooms within the premises shall have a level threshold. If a stepped threshold is necessary it shall be designed as follows.

7.1.4.1 Stepped thresholds

When a stepped threshold is required and the change in level is 20 mm or less, no ramp is required. A strong visually contrasted strip shall be incorporated that is effective when approaching from either direction.

7.1.4.2 Ramped thresholds

If the change in level is greater than 20 mm a ramp is required which shall have a gradient not steeper than 1 in 8 and a going of not more than 450 mm (see figure 17).

7.1.5 Revolving doors

7.1.5.1 Side door

Where a revolving door or turnstile is installed a hinged or sliding door shall be provided as an alternative alongside (see figure 18). The alternative side door shall have an access sign to identify it as the accessible entrance and shall be unlocked during normal building occupation. (Also refer to 4.10.4.1.)

C7.1.1

Entrances also serve as exits, some of them being particularly important in an emergency. It is preferable that all entrances should be usable by people with disabilities.

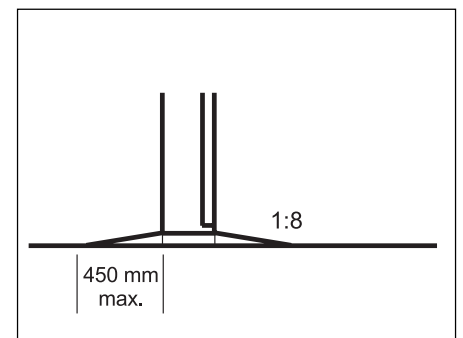

Figure 17 – Threshold ramp

C7.1.4.2

Thresholds and surface height changes in doorways are particularly inconvenient for wheelchair users, who may have low stamina or restrictions in arm movement. Complex manoeuvring is required to get over the level change while operating the door and negotiating the space on the other side.

C7.1.5.1

Most revolving doors are difficult for wheelchairs, scooters, prams, trolleys, and people with walking aids. A normal side-hung door installed as per 7.1.5.2 will allow access.

C7.2.1

The corridor width of 1200 mm allows space for its use by people with disabilities and the aids they require, e.g. for a wheelchair and an ambulant person to pass, for a blind or aged person with a carer to walk side by side, or for a blind person and guide dog to use. This minimum width is also essential to allow a wheelchair to make a 90° turn into a doorway in one movement.

C7.3.1

If the door is a standard side-hung door that opens 90°, the clear width may be achieved by the use of an 810 mm single leaf door. If the door is pivot hung or otherwise fitted with hardware that will restrict the clear opening width, the door leaf size required increases to 860 mm. This is particularly relevant to sliding doors (see figure 20).

Wider clear openings of doorways, e.g. 810 mm, are recommended at entrances and throughout buildings. This is to allow for larger wheelchairs used by an increasing number of people with disabilities. There is also an increasing use of motorized scooters.

New Zealand manufactured stock doors of 860 mm give a clear opening of 810 mm.

In practice the majority of the exterior doors of public buildings have a clear opening of at least 860 mm.

7.1.5.2 Side panel to side door

If the side door is to be installed adjacent to a return-wall and if the door handle is to be on the side of the door adjacent to the return wall then a side panel, situated between the side door and the wall shall be provided (see figure 18). The minimum width of side panel shall be 300 mm.

7.2 Corridors

7.2.1 Minimum width of corridor

All corridors on accessible routes within a building shall have a minimum width of 1200 mm.

7.2.2 Length of corridor

There shall be a minimum corridor length of 1200 mm plus the width of the door (if it opens inwards), between one doorway and the next that cross a corridor and/or form a lobby (see figure 19).

7.3 Doorways

7.3.1 Clear opening

The minimum clear width of a doorway shall be 760 mm when the door is open (see figure 20).

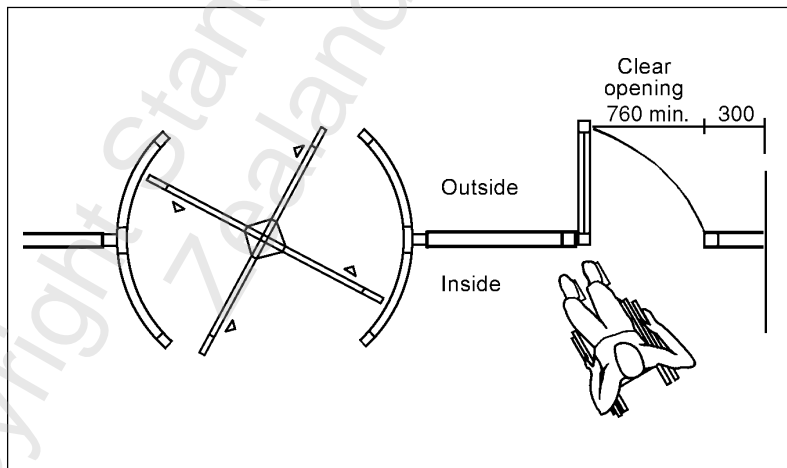

Figure 18 – Revolving door with side hung door

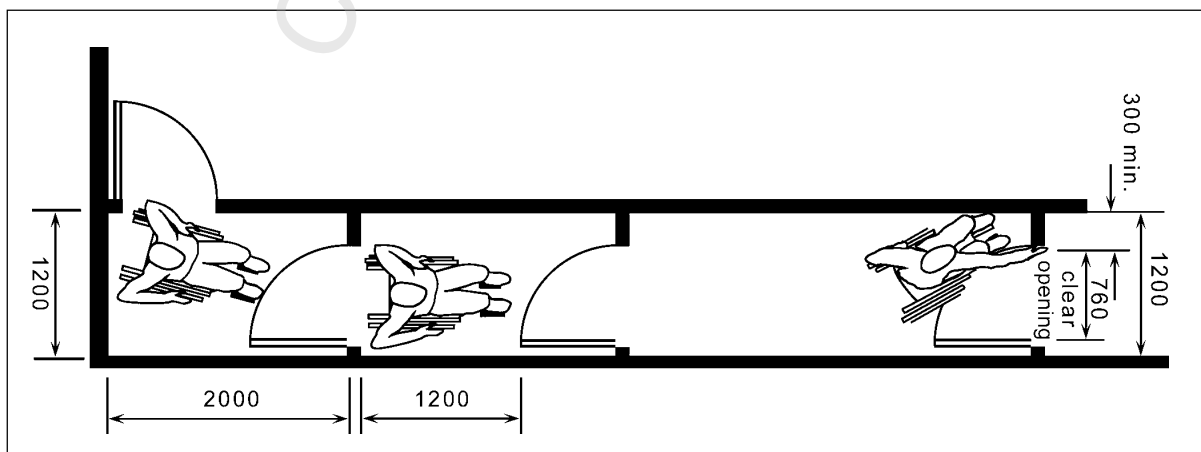

Figure 19 – Space requirements in confined spaces

7.3.1.1 Double doors

Double doors on an accessible route shall have at least one leaf that provides a minimum clear opening of 760 mm, refer to 7.3.1.

7.3.2 Door glazing

The glazing of doors shall comply with NZS 4223:Part 3 for human impact safety, in particular:

- (a) Doors that swing in both directions shall incorporate glazing to provide adequate visibility for people with disabilities.
- (b) Whenever transparent glazing material may be mistaken for a doorway or for an unimpeded path of travel, they shall be clearly marked as required by NZS 4223.3, clause 303.1.

C7.3.1.1

If necessary the leaf sizes will be unequal to permit the larger and 'opening' leaf to comply.

C7.3.2(b)

Ideally, glazing should carry discernible patterning over most of the surface to allow for detection by people with severe loss of sight in discrete areas of the field of vision.

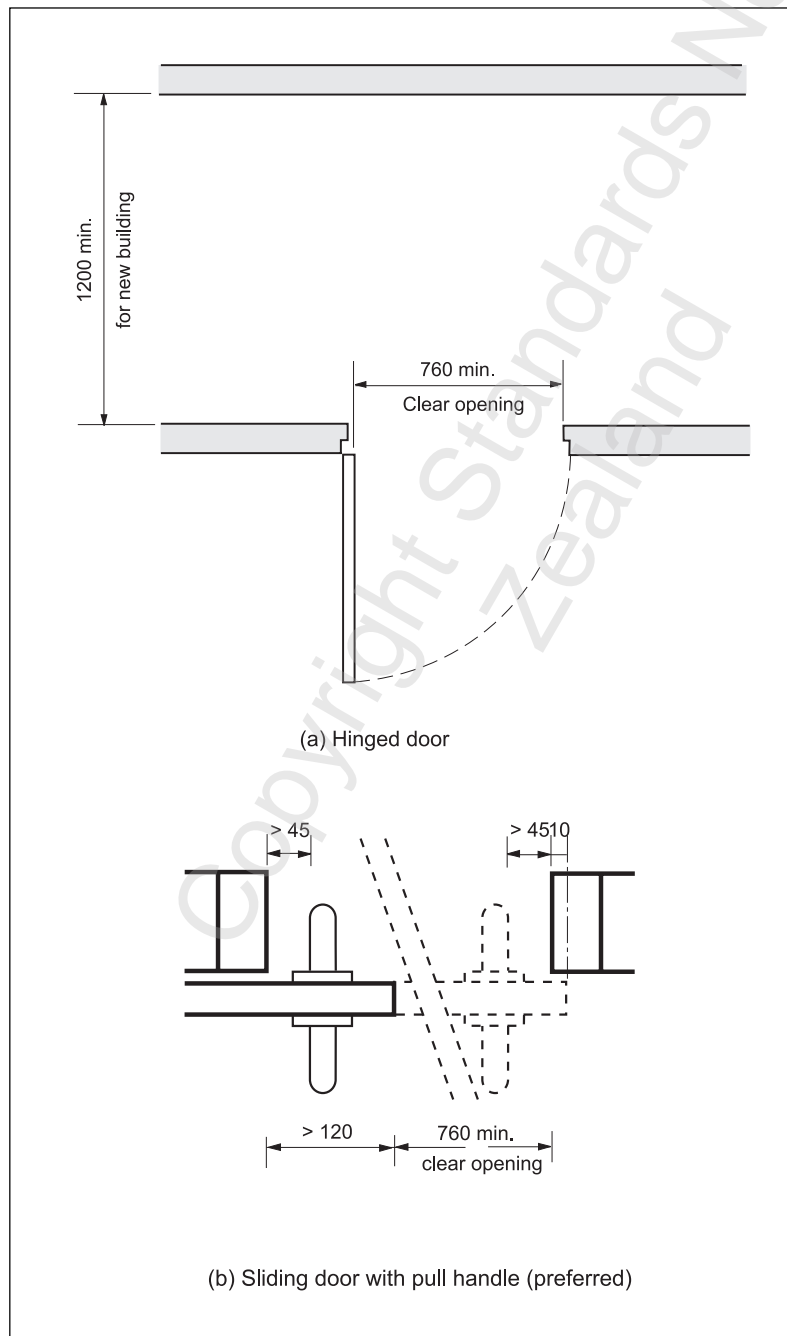

Figure 20 – Clear width of doorway

- (c) Figure 21 – Minimum glazing in doors on accessible routes shall apply but within certain building types e.g. hospitals, childcare centres, the lower dimension of glazing may need to be varied.

7.3.3 Offset of doors

Where a door opens back into an enclosed space, an unobstructed wall space of not less than 300 mm shall be provided at the side of the door adjacent to the handle (see figure 19).

7.3.4 Doorways to rooms

7.3.4.1 Doorway in corridor wall

When circulation spaces are equal to or greater than 1200 mm, the minimum clear width of a doorway to allow general access shall be 760 mm, refer to 7.3.1 and figure 20.

7.3.4.2 Recessed doorways

Any recessed doorway over 600 mm in depth shall be treated as a doorway across a corridor.

7.3.4.3 Visibility

Doors shall be of a clear colour contrast with respect to their surroundings, refer to 4.10.4.

7.3.5 Forces required

The force required to push or pull open a non-fire door shall not exceed the following:

- (a) Exterior hinged door: 38 N;

C7.3.4.3

An important visibility factor for doors is the opening contrast. (Lighting can be used to define this.)

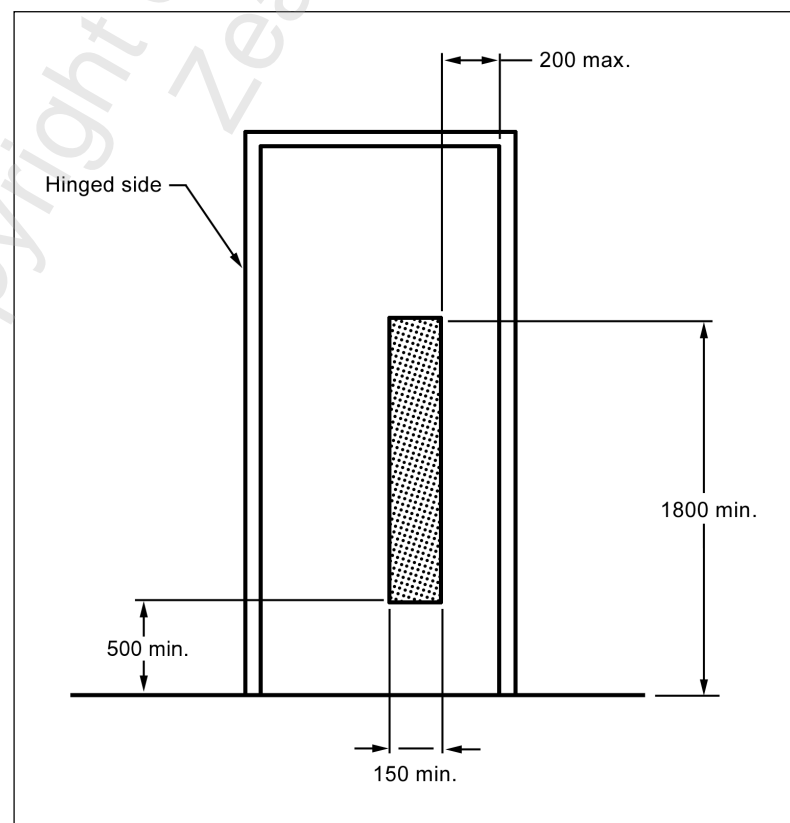

Figure 21 – Minimum glazing in doors

- (b) Interior hinged door: 22 N;
- (c) Sliding or folding doors: 22 N.

7.3.6 Fire and smoke control doors

The force necessary to keep them shut and so be effective in a fire may not be easily overcome by people with disabilities. Studies suggest that a force of 70 N could be handled by up to 80 % of people with disabilities, and a force of 21 N could be handled by 95 % of the people with disabilities. In a pressurised situation the use of barometric relief dampers or other pressure regulating methods may be required. Wherever possible consideration should be given to the installation of complying hold open devices.

C7.3.5

These forces taken from ANSI A117.1.

Calculation of the correct size of door closer is based on the width of the door. The wider the door the stronger the door closer force required. The formula for calculating the force necessary to close a door against a known air pressure is:

$Force = (P \times A \times W) / 2$, where P = air pressure (pascals), A = surface area of door, w = width of door.

Table 1 of BS EN 1154:1996 identifies seven power sizes of door closer with various forces. Table 1 applies only to interior doors under ideal conditions so the door closer should be adjusted to a higher power setting where it is used as an exterior door and in windy or draughty interior conditions. For exterior doors, adjustable power sizes 2 – 6 and for interior doors, adjustable power sizes 1 – 5 are recommended.

Attention to the manufacturer's instructions is vital where installing door closers. Ongoing maintenance is necessary to adjust and maintain the required forces for both closing and latching a door.

There is a 'push-pull' device available to installers and building owners for measuring door closer forces.

7.3.7 Door handles and hardware

Door handles and related hardware and accessories shall comply with the following requirements:

- (a) Handles shall be between 900 mm and 1200 mm (optimum 1000 mm) above the finished floor level;
- (b) Handles operating locks and latches shall have a lever action and the end of the handle shall be returned towards the door;
- (c) The door opening pressure shall be the minimum required to suit specific use and conditions (refer to 7.3.5).

C7.3.7

For devices such as a delayed action door-closer, rising-butt hinges are recommended.

Doorknobs with a twist or turn action or recessed handles do not provide an adequate grip for people with limited or reduced hand function.

C8.1.1

Spiral or open riser stairs can be hazardous for elderly people and others prone to dizziness and vertigo. In addition people who wear leg braces or prosthetic devices need a solid riser to guide the foot up over the riser to the next step and to maintain balance. Those who use crutches place them against the riser of the step above the one they are on.

Appendix G shows an example of a service core plan with scissors stairs, a common design of stair in public buildings.

8 STAIRS**8.1 General****8.1.1**

In all buildings where there is more than one floor a minimum of one accessible stair opening off an accessible route shall be provided whether or not lifts are installed.

Spiral and open riser stairs shall not be used for this purpose.

8.1.2 Design

Appropriate and safe stair design, whether aimed at achieving the best design for the public at large or for those members of the public who have disabilities, shall have features as shown below (also see figure 22):

- Steps that can be readily seen by all users with some useful vision;
- Treads large enough to provide adequate footing;
- Reachable, graspable handrails;
- Landings of reasonable size;
- Stair flights of limited length;
- Visual and tactile cues at top and bottom of each set of stairs and on nosings of treads;
- Lighting that reduces glare from point sources such as unshaded windows and exposed lamps shall be avoided and reflective polished surfaces minimized.

8.2 Single steps

There shall be no single steps.

8.3 Stair design

The basics of good stair design are shown in figures 22 and 23.

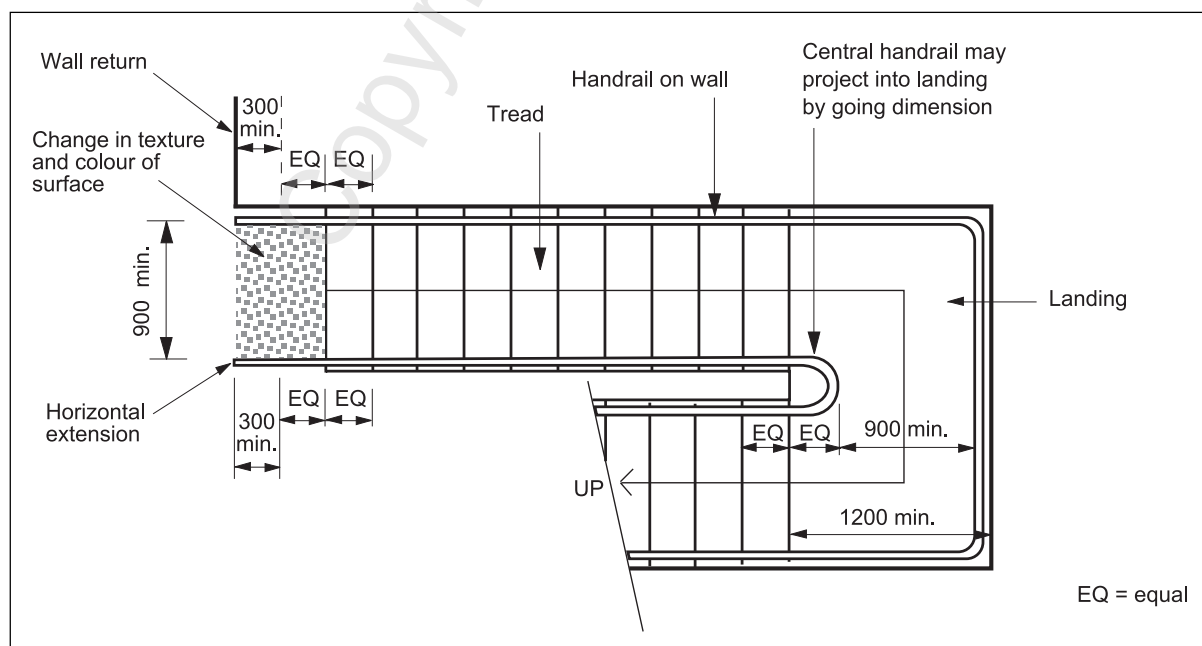

Figure 22 – Good stair design

8.3.1 Pitch

The angle of pitch of stairs is measured between the horizontal and the pitch line, a line connecting the nosings of all treads in a flight (see figure 23).

8.3.2 Height

The total rise of any flight of stairs shall not exceed 2500 mm.

8.3.3 Top and bottom steps

The line of the nosing of the top step of a flight of stairs shall not be closer than 300 mm to the point where an adjacent wall returns, and the bottom riser of a stair shall not be closer to an adjacent wall return than 300 mm plus the dimension of a tread (see figure 22).

8.3.4 Encroachment into corridors

The top or bottom step of any flight of stairs shall not encroach into corridors so that the effective minimum width of the corridor on accessible route or means of escape in fire is compromised. Where stairs do encroach, they shall be protected by a barrier, or a return wall indicated by a change in surface texture of the floor.

C8.3.1

The pitch is a product of the step profile (see figure 25).

C8.3.2

The purpose of this limitation is to ensure that there is an intermediate landing for safety and comfort.

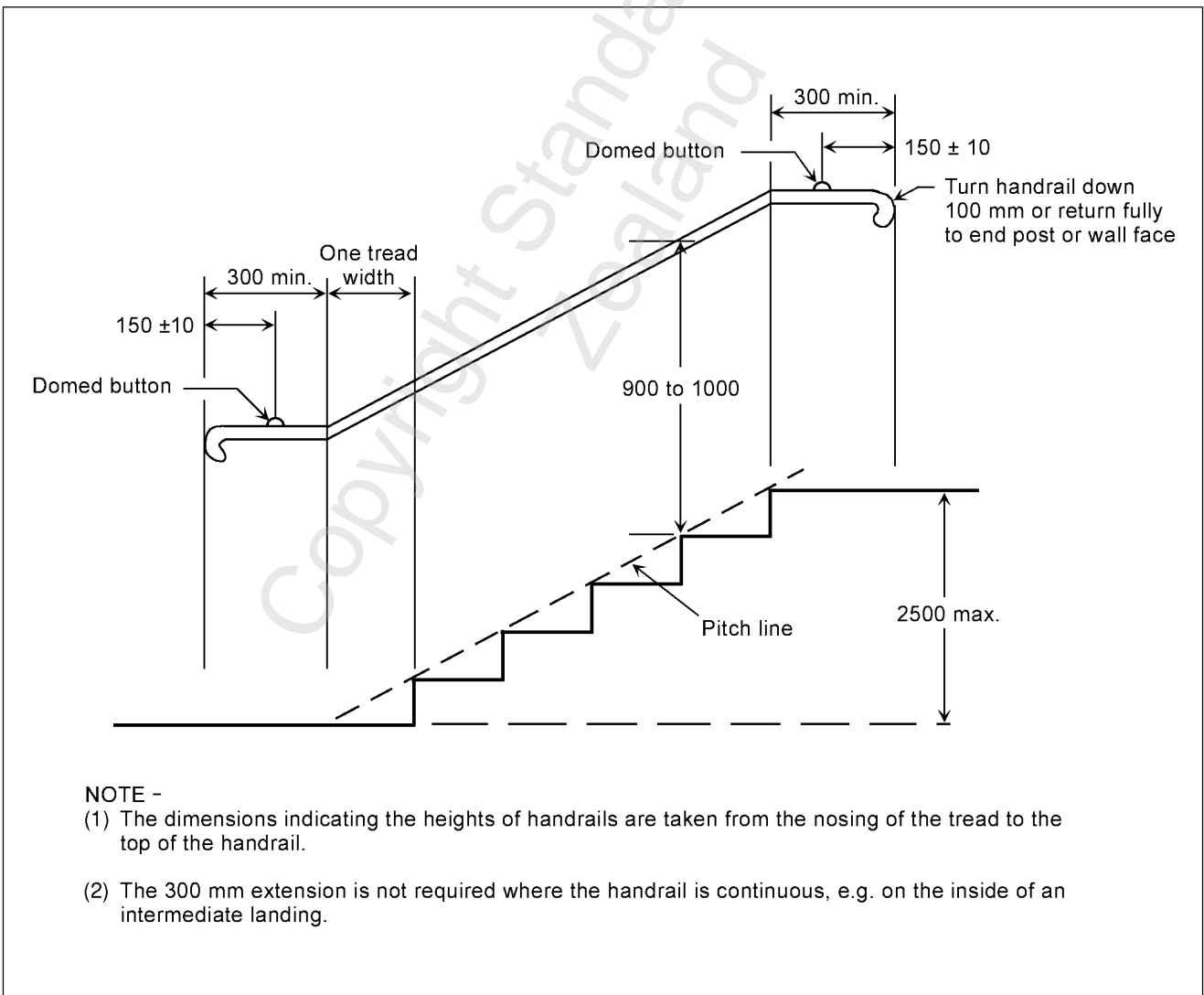

Figure 23 – Pitchline and extension of handrails

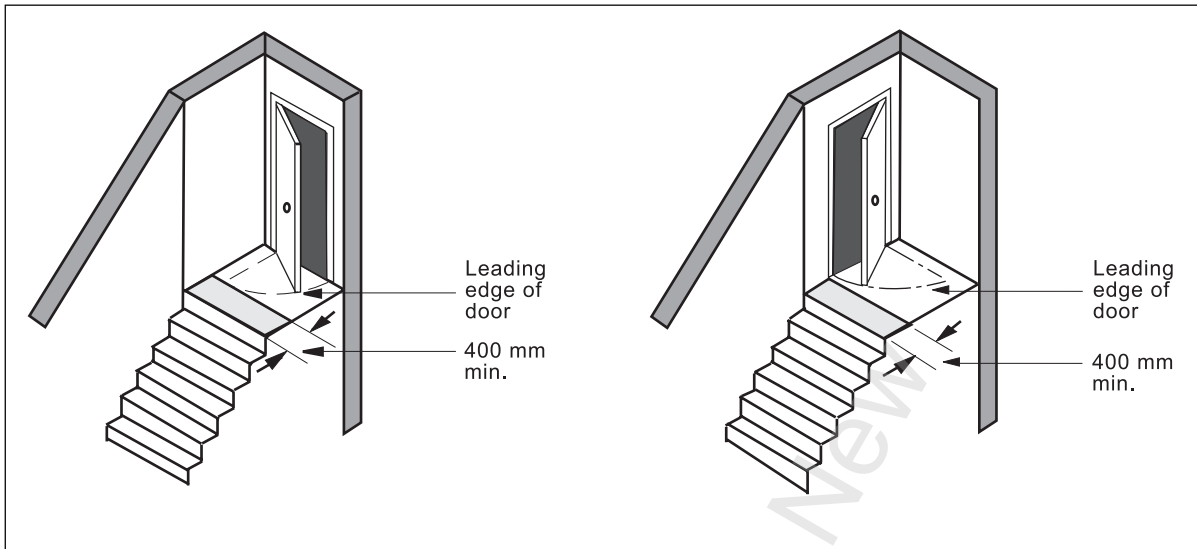

Figure 24 – Opening of doors

C8.3.6.1

Section 21A of the Fire Service Act 1975 requires evacuation plans to include people with disabilities.

8.3.5 Opening of doors

No door shall open directly across the top of a flight of stairs or swing so that it obstructs the top or bottom step unless there is a clear width of 400 mm between the fully open door and the top or bottom of the stair (see figure 24).

8.3.6 Landings for stairs**8.3.6.1**

Landing lengths of at least 1200 mm (including mid-flight landings, whether on a straight or zigzag set of stairs) are required to ensure that wheelchair users may be safely carried down (up) stairs in their own wheelchairs in an emergency, (generally the preferred evacuation method). This length ensures both a safe resting-place for the wheelchair user and enables other people to pass safely.

8.4 Stair construction**8.4.1 Width of stairs**

The minimum width between handrails on stairs shall be 900 mm (see figure 22).

8.4.2 Risers and treads

The steps of a flight of stairs shall be in accordance with the following requirements:

- (a) Risers and treads shall be uniform for all steps in any one flight;

A 5 mm variation in riser height can cause stairs to become less safe, even if it is the very top or bottom riser that is a different dimension.

- (b) Staircases shall have maximum rises of 180 mm and minimum tread of 310 mm in accordance with figure 25.

8.4.3 Nosings

Nosings shall be rounded and not project more than 25 mm (see figure 25).

8.5 Provision of auditory and visual cues

8.5.1 Surface treatment

A change in surface treatment with strong colour contrast shall be provided at the head and foot of any internal flight of steps (see figure 22).

8.5.2 Stairwells

Strategic changes in the auditory environment shall also be used to help people identify the presence of the stairwell – especially the more potentially dangerous head of the flight.

8.6 Handrails

8.6.1 General

Handrails shall be provided on both sides of accessible stairs and steps.

8.6.2 Design

8.6.2.1 Size and shape

The design of the handrail shall meet the requirements of Appendix F. Handrails shall be continuous (also refer to 8.6.3) with no obstructions to the movement of the hand along its length. Dome buttons shall be provided as shown on figure 23.

C8.4.3

Nosings with sharp or abrupt angles or projecting risers prevent the sliding foot action described in C8.1.1 and can cause tripping.

C8.5.1

This assists people with a vision impairment to negotiate the stairs safely and smoothly. For general safety unexpected protrusions and significant changes in slip resistance should be avoided. For carpeted areas, a flush warning surface with similar slip resistance but a corduroy patterning running across the line of travel could be considered.

C8.5.2

The placement of specific sound sources such as fans at this point can act as useful cues. The use of harder, more reflective surfaces in the stairwell walls and ceiling in comparison to the connecting corridors may also assist through emphasising the presence of sound sources within the well or other people using the stairs. (For further information refer to 4.10.5.2.)

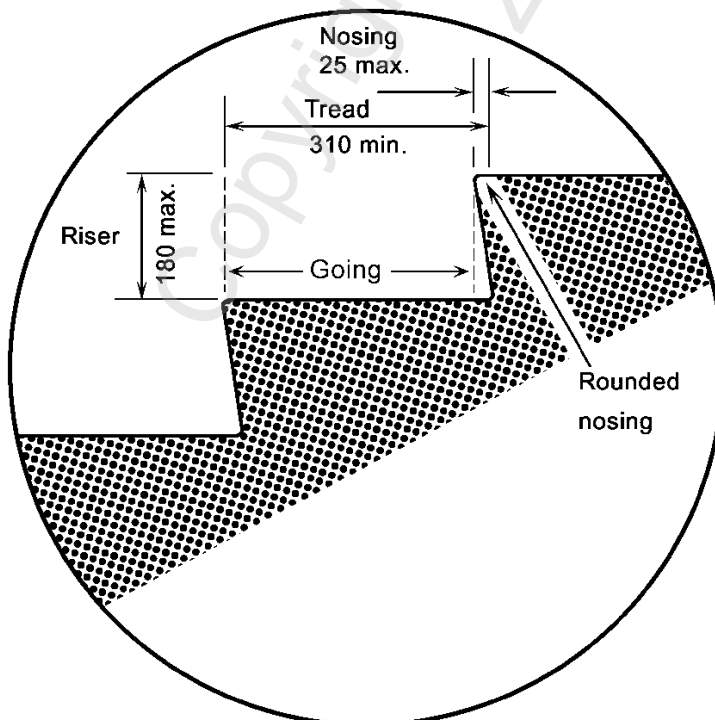

Figure 25 – Basic profile of stairs

C8.6.3

Handrails on both sides of stairs and ramps are necessary for people with disabilities who may have a right-handed or left-handed capability.

A handrail on each side also enables some people with locomotive problems to swing down narrow stairs. This is a very quick and efficient process for those who can perform it, especially when quick egress is needed in an emergency.

C8.6.4.3

The dimensions indicating the heights of handrails are taken from the nosing of the tread to the top of the handrail.

C8.6.5.1

The 300 mm minimum horizontal extension is the critical dimension, with the one going extension at the bottom being required to ensure that the horizontal extension is at the same height as the handrail on the stair.

The horizontal extensions are required as a safety issue:

- (a) To protect people from moving traffic, thus avoiding the hazard of being pushed over at the top of a flight of stairs. The handrail extensions at the bottom of a flight of stairs as shown in figures 22 and 23, serve the same safety purpose;*
- (b) The handrail extensions also serve the purpose of clearly indicating both the start and the finish of the stair.*

The 300 mm extension is not required where the handrail is continuous, e.g. on the inside of an intermediate landing.

C8.6.5.2

The projection shown in figure 22, avoids the sudden increase or decrease in the height of the handrail as it makes the 180° turn up or down the stair.

8.6.2.2 Contrast

Handrails shall contrast visually to their background, refer to 4.10.

8.6.2.3 Projecting ends

Handrails shall not have projecting ends that will create a hazard. The ends of handrails shall be turned down 100 mm or returned fully to the end-post or wall face.

8.6.3 Position

Stairs and ramps shall have handrails on both sides, which shall be continuous around landings (see figure 22), except at doorways.

8.6.4 Installation**8.6.4.1 Position**

The handrail shall be installed parallel to the entire pitchline of the stairs (see figure 23).

8.6.4.2 Clear space

The clear space between a handrail and the adjacent wall surface shall be 50 – 60 mm at the sides and 100 mm above.

8.6.4.3 Height

The height of a handrail above the nosing of the tread shall be between 900 mm and 1000 mm (see figure 23).

8.6.5 Extensions**8.6.5.1 Position and size**

Horizontal extensions to the handrail commence after the completion of the pitchline as measured vertically at the top and bottom of the flight of stairs (see figure 23). The length of an extension shall be 300 mm minimum at the top step and 300 mm plus the going at the bottom step.

8.6.5.2 Encroachment

Handrails shall not project into any other path of travel, except when a centre handrail projects into a landing by the distance of the stair going.

8.6.6 Fixing

Handrails shall be securely fixed and rigid. A handrail shall be able to support a weight of 110 kg. (Refer to Appendix F.)

Handrails shall be fixed so that there is no obstruction to the passage of the hand along the grip.

9 LIFTS

9.1 General

9.1.1 Lifts

All accessible lifts shall comply with 9.2 of this Standard, with NZBC D2.3.5 and NZS 4332.

Platform lifts and stair lifts shall not be used as an alternative to this requirement.

9.1.2 Signs

Accessible lifts shall be clearly sign-posted.

9.1.3 Provision of lifts

9.1.3.1 General

An accessible route shall include a lift to upper floors where:

- (a) Buildings are four or more storeys high;
- (b) The upper floor(s) of any building are to be used as the public reception areas of:
 - (i) Banks
 - (ii) Central government offices or government agencies
 - (iii) Regional government offices
 - (iv) Local government offices and facilities.
- (c) The upper floor(s) are designed or intended to be used as:
 - (i) Public areas of hospitals, medical consulting rooms, dental surgeries, and other primary health care centres
 - (ii) Places of public assembly for 250 or more people
 - (iii) Public libraries.

9.1.3.2 Two and three storey buildings

Where 9.1.3.1 is not applicable a lift is not required when:

- (a) Buildings are two storeys high and have a gross floor area of the upper floor of less than 400 m²;
- (b) Buildings are three storeys high and have a gross floor area of the upper floors of less than 500 m²;

provided that the ground floor complies with the requirements of this Standard and the upper floors have access for ambulant people with disabilities.

9.1.4 Lift cars and lift installation

The NZBC requirements for mechanical installations on accessible routes are defined in NZBC Clause D2, D2.3.5 (refer to Appendix B).

C9.1.1

The requirements relating to lifts in buildings to which the access requirements apply, have the effect of requiring lifts to be designed so that they are usable by all users, whether they have disabilities or not.

C9.2.2.1

The minimum dimensions of the lift car as shown in this Standard allow an attendant and other passengers to use the lift at the same time as a wheelchair user. This size does not allow many wheelchairs to turn through 180°.

C9.2.3

The door width of 900 mm shown in figure 26, is required so that a wheelchair user can easily enter the lift during the pause period of 5 seconds. The width and depth of the lift car are also designed to promote ease of entry.

C9.2.4

Tactile and visual controls assist blind people and others with impaired vision. Such control buttons can be designated by raised or indented standard alphabet characters or letters.

9.2 Design

Figure 26 shows the main requirements for lifts, but these should not prevent other designs, systems and technological developments from being permitted. The Standard does not specify all the requirements for an accessible lift, i.e. its speed or its construction.

9.2.1 Lift foyer

The unobstructed depth of floor in front of lift doors shall be not less than 1800 mm.

9.2.2 Lift cars**9.2.2.1 Size**

Lifts serving an accessible route shall have a minimum interior clear space of 1400 mm by 1400 mm as shown in figure 26.

9.2.2.2 Levelling accuracy

The levelling accuracy of the lift car at each landing shall be within a tolerance of + or – 20 mm under all loading conditions.

9.2.3 Lift doors

The lift door installation shall provide for the following:

- (a) Lift doors shall open sideways and be power operated;
- (b) Lift doors shall provide a minimum clear opening of 900 mm;
- (c) The doors shall remain open for not less than 5 seconds before the passenger protective device becomes operative;
- (d) Passenger protective devices shall be provided to ensure that car and landing doors will not close while the opening is obstructed, subject to the delayed closing provisions which operate if the door is held open for more than 10 seconds; and
- (e) Lift doors shall be of a clear colour contrast with respect to their surroundings.

9.2.4 Lift controls

Lift controls, whether in the lift lobby or in the lift car, shall be situated between 900 – 1350 mm above floor level (see figure 26). Controls shall comply with the following requirements:

- (a) Call buttons shall have a tactile distinction from the faceplate. Buttons shall have a positive movement for actuation and shall have a width or diameter of not less than 20 mm.
- (b) Raised or indented designations for control buttons shall be placed immediately to the left of the button to which they apply and shall have a minimum height of 15 mm, see figure 26;
- (c) The alarm button or emergency telephone shall not be higher than 1350 mm above finished floor level;
- (d) Designations in Braille shall be placed immediately to the left of the standard designation.

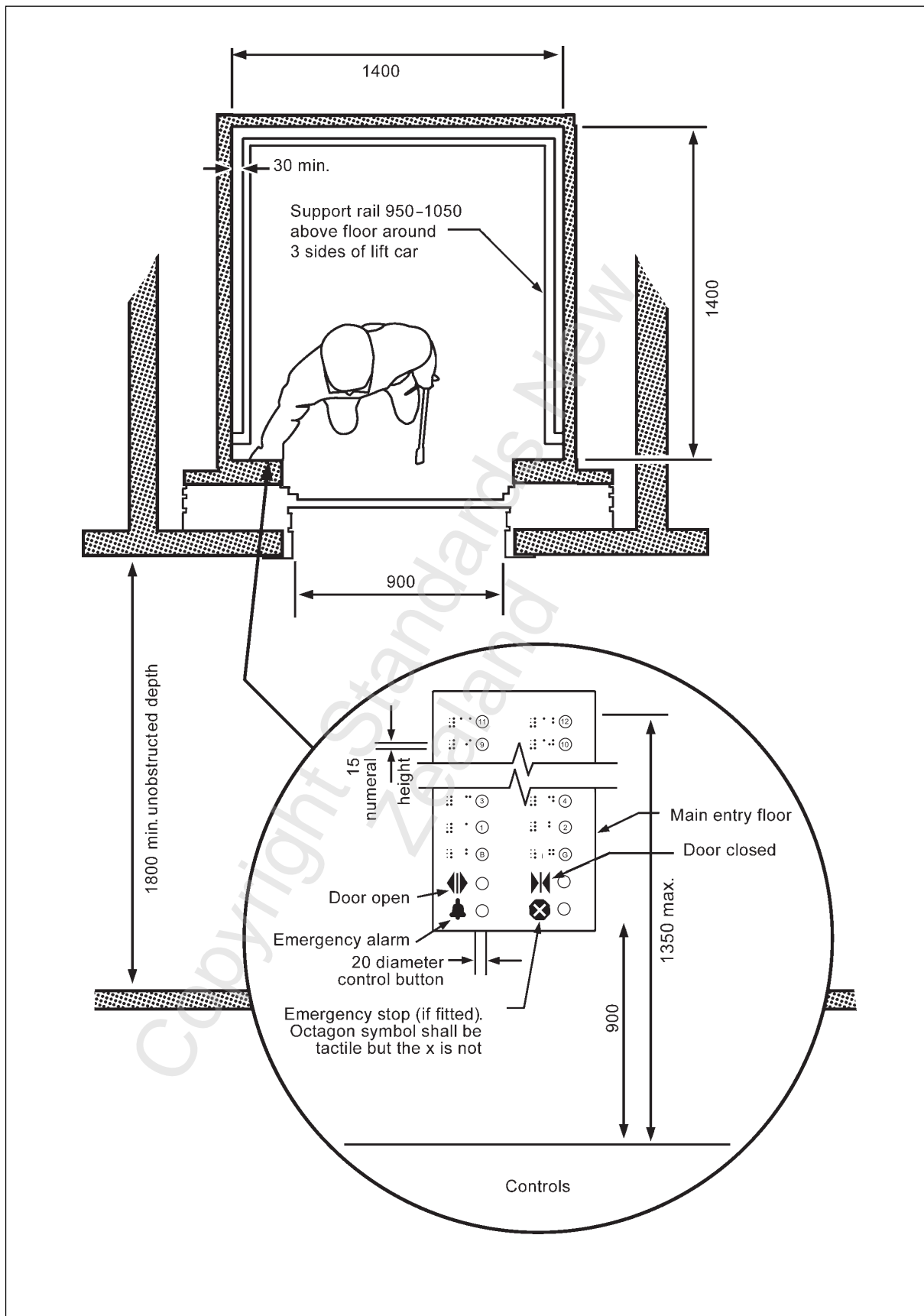

Figure 26 – Lift car dimensions and control panel

9.2.5 Lift indicators

Lift indicators shall be provided as follows:

- (a) 'Lift coming' or 'call accepted' indicator. These shall be provided at each landing.
- (b) 'Lift arrival' and 'lift direction' indicators. These shall be provided at each lift landing and shall be signalled in advance both visually and audibly. The visual signal shall be an illuminated arrow. The audible signal shall be two gongs to indicate downward travel and one gong upward travel.
- (c) Lift position indicator. A visible and whenever possible, audible lift position indicator shall be provided. The visible position indicator shall be fitted in the lift so those passengers facing the main doorway can easily read it.
- (d) Floor indicators. In all cases where audible signals e.g. voice announcements, of floor level are not used, raised tactile numbers shall be provided on the leading edge of landing doors, or on the entrance architrave as close as practical to the landing doors, to indicate the floor level position of the lift. These tactile numbers shall have a raised profile, be not less than 20 mm in height and shall be sited 1350 mm above finished floor level.

In this situation, tactile numbers on the leading edge of the lift door are the only way a blind person can find out what floor the lift has stopped at.

On any lift covering more than three floors on an accessible route an audible indication of floor level shall be used. It is preferable that audible indicators are also used on lifts of only two and three storeys.

9.2.6 Support rails

Support rails shall be provided in lifts. Support rails shall be on all walls except those in which doors are installed. Such rails shall provide for a minimum clear finger space of 30 mm from the wall surface, have a recommended diameter of 30 – 40 mm, and shall be installed between 950 – 1050 mm above the finished floor level.

10 TOILET AND SHOWER FACILITIES

10.1 General

All accessible toilet facilities shall be provided on an accessible route.

This Standard recognizes two main types of toilet facility:

- (a) Facilities with separate WC cubicles and/or urinals and separate wash hand basins plus an accessible unit with internal handbasins. These are usually gender-specific;
- (b) A toilet facility based on a number of self-contained toilet units each containing at least a water closet and a hand basin. These may be all-gender or gender-specific.

In addition toilets may contain showers and parenting facilities.

10.2 Location

10.2.1

Accessible toilet facilities shall be provided on the main entry level to all buildings. In addition, in multi-storey buildings additional accessible toilets shall be distributed evenly and throughout the building. Alternatively, wherever toilets are provided at least one shall be an accessible toilet.

10.2.2

Accessible toilets shall be provided such that the route to them shall not traverse different tenancies within the building.

10.3 Signs

Accessible toilet facilities shall be sign-posted (refer to 4.8).

10.4 Number of toilets and showers

The number of accessible toilets and showers to be provided shall comply with NZBC G1/AS1. At least one all-gender accessible toilet unit shall be provided that can be reached without going through an area reserved for one gender.

10.5 Design

10.5.1 General

This section defines minimum requirements to produce a desired end result. In some cases there may be alternative ways of achieving this result.

C10.1

The design of toilet and shower facilities is intended to provide for unaided use by a person with a disability.

C10.4

In most buildings with fewer than 300 occupants, one all gender accessible toilet is sufficient. For larger buildings another all gender toilet should be provided but when sanitary facilities are provided in groups of two or more locations, accessible facilities should be provided at each location.

The principle advantage of an all-gender facility is the ability to use the facility accompanied by a helper of the opposite gender. In addition there should be greater utilization of the facility since it is available to all people.

All-gender toilets are recommended in all situations especially in those areas used by the general public (for example shopping areas).

The provision of accessible toilet units and shower units may be individual or in any combination with each other to suit design requirements. It is recommended that combined shower/toilet units be used if a shower is required.

NZS 4241 covers the calculation of the number of toilet units required (including accessible units) in public toilets in general, and is useful for areas outside those defined in NZBC G1/AS1.

C10.5.4

The floor dimensions in the toilet layout shown in this Standard are minimum measurements and may be increased. If nappy changing tables are to be provided then the floor area will need to be increased so that manoeuvring space is not obstructed.

NZS 4241 provides examples of accessible toilet unit floor dimensions that are based on experience and are greater than the minimum requirements. The Standard also gives examples of alternative positioning of toilet fixtures and fittings.

10.5.2 Accessible toilets

Accessible toilets shall be designed to provide manoeuvring space so that people in wheelchairs may use each type of fixture, refer to 10.5.4.

Accessible toilet units allow:

- Use by anyone;
- Increased ease of use because the larger floor area that allows a wheelchair to turn through 360° in one movement;
- Greater utilization of the facility because of the larger size of the unit permits its use as a family/parenting room.

10.5.3 All-gender accessible toilet units

The provision of at least one all-gender accessible toilet unit is a requirement of all toilet facilities.

10.5.4 Dimensions

Accessible toilet units shall have sufficient space to allow wheelchair users to transfer to the toilet pan from the side of the pan; to approach and use the pan from the front; and for use by a commode.

The minimum dimensions of a compartment shall be 1900 mm by 1600 mm (see figure 27).

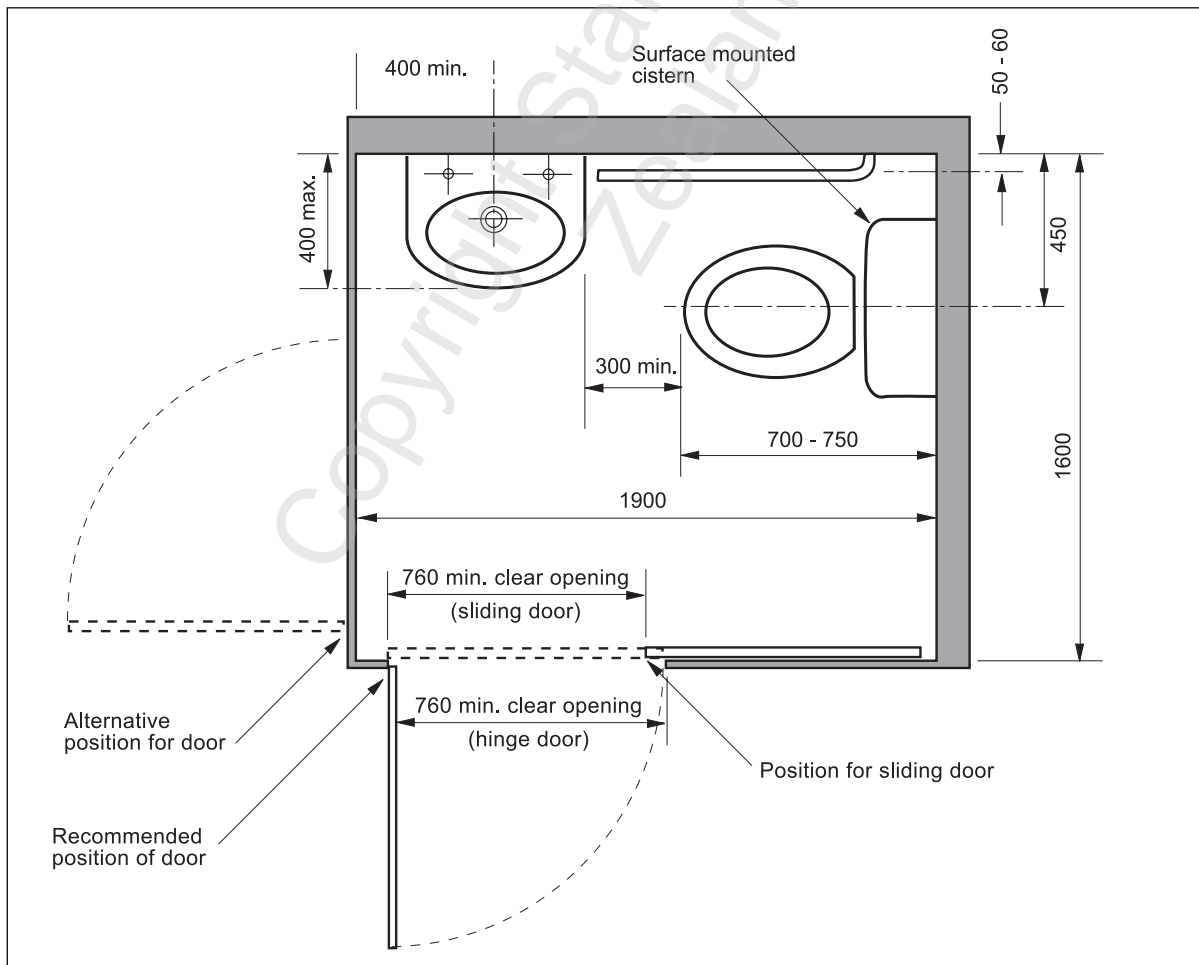

Figure 27 – Accessible toilet units

10.5.5 Toilet doors

All doors serving toilet facilities shall:

- (a) Be provided with a suitable indicator bolt of suitable size and simplicity of operation to be readily usable by those with limited hand movement;
- (b) Be able to be opened from the outside in an emergency;
- (c) Have pull rails and kick plates as shown in figure 28.

C10.5.5

An outward-opening door is preferred. Inward opening doors can only work effectively if there is a turning circle space of 1500 mm diameter beyond the open door.

10.5.6 Toilet pans

If two or more accessible toilet units are provided at least one shall have a pan position of the opposite hand, refer to 3.3.2.

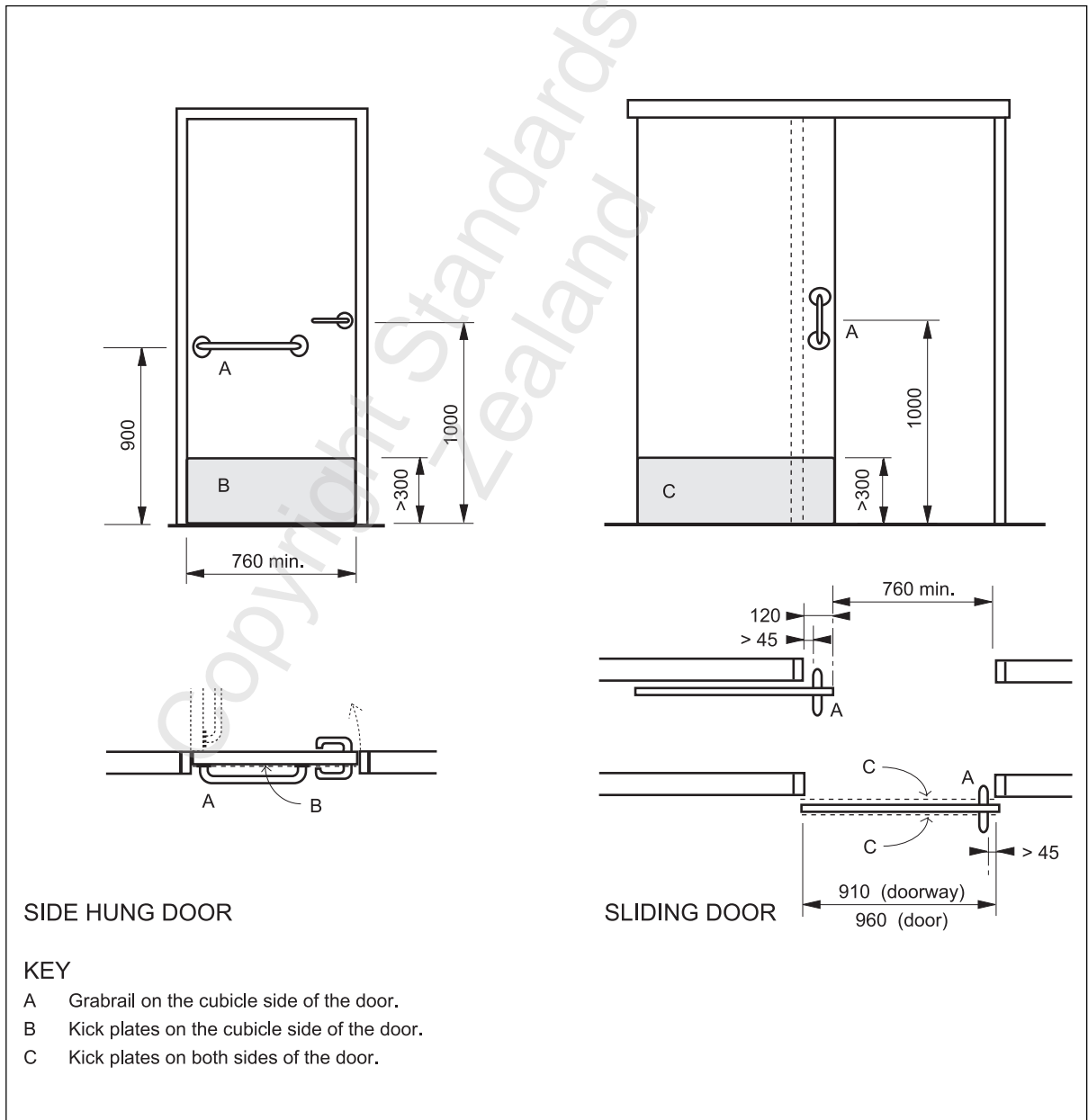

Figure 28 – Grab rails and kick plates on toilet doors

C10.5.6.1

Side-trunked or side-vented toilet pans should be avoided to permit the use of a commode, when required. This applies to any obstructions at the side of the pan.

C10.5.6.3

False wall provides back support.

10.5.6.1 Siting

The toilet pan shall be sited so that:

- The front edge of the toilet seat shall be 700 – 750 mm from the back wall;
- The centre-line distance of the toilet seat from the nearest side-wall shall be 450 mm;
- There is no obstruction at the side of the pan to inhibit the use of a commode;
- There is no obstruction at the back of the pan to inhibit the use of a commode;
- The front edge of the toilet seat is 300 mm minimum from the wash basin except as provided in 10.5.8;
- The toilet lid is supported between 10° and 15° beyond the vertical to provide a backrest for the user.

10.5.6.2 Height

The height of the top surface of the toilet pan seat shall be 460 mm.

10.5.6.3 Wall-hung pans

Wall-hung pans shall be fixed on a false wall (see figure 29) and comply with 10.5.6.1. If there is no false wall, a seat bracket is required.

10.5.6.4 Flushing control

The flushing control shall be easily operable, and positioned as in figure 32.

10.5.7 Urinals

If accessible urinals are to be provided, they shall be constructed without a step and at least one stall shall be fitted with a horizontal grab rail. There shall be a clear space at least 760 mm wide and 1200 mm deep in front of the urinal.

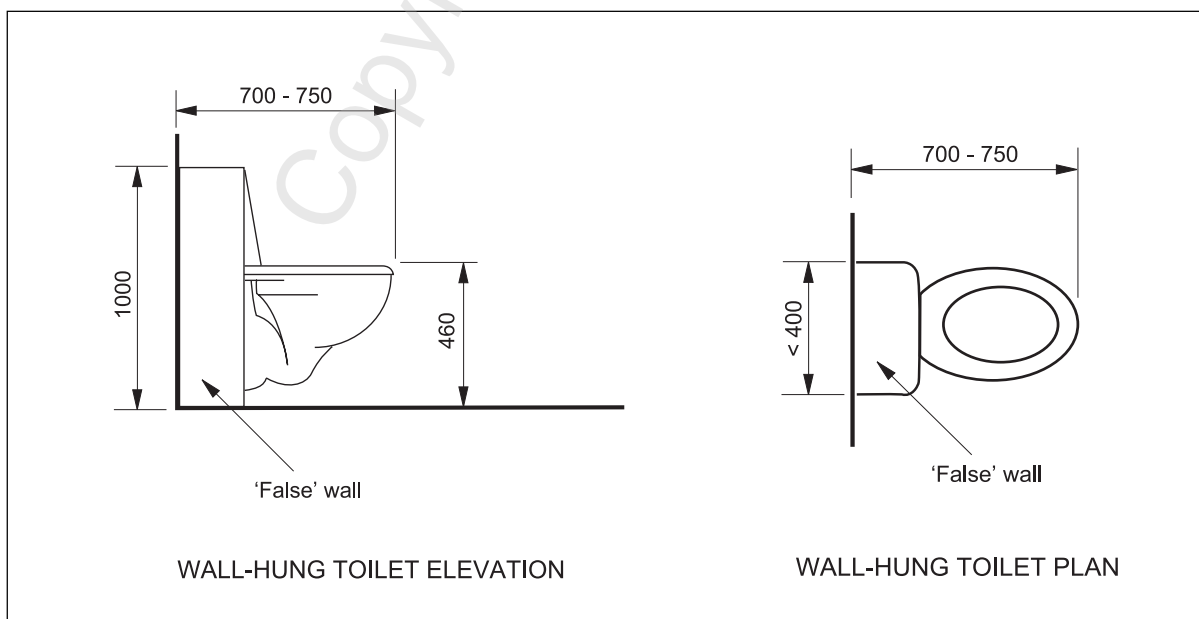

Figure 29 – Wall hung pans

10.5.8 Washbasins

10.5.8.1 Standard washbasin

Standard washbasins, having a maximum depth of 400 mm, shall comply with AS/NZS 1730 and be installed so that:

- (a) The centre line of a washbasin is at least 400 mm from a wall forming a return to the wall on which it is fixed (see figure 27);
- (b) Washbasins shall provide a minimum clearance of 675 mm on the underside as shown in figure 30;
- (c) Water supply pipes and waste outlets do not encroach on the required clear space under the washbasin;
- (d) Exposed hot water pipes are to be insulated or otherwise covered;
- (e) There is a clear space at least 760 mm wide and 1200 mm deep in front of the basin;
- (f) Near to the toilet with its nearest edge 300 mm minimum away from the front of the toilet pan (see figure 27).

10.5.8.2 Provision of water

The washbasin shall be provided with:

- (a) A mixed flow of water delivered through a central outlet;
- (b) A maximum water temperature of 55 °C at delivery point. Refer to G12/AS1.
- (c) All controls at 50 – 60 mm clearance from any obstruction;
- (d) If taps are provided:
 - (i) They shall have lever or capstan handles easily operated by a person with limited hand function;
 - (ii) The hot water tap shall be placed to the left of the cold water tap.
- (e) Plugs shall be connected to, or form, part of the washbasin.

C10.5.8.1

In this case a washbasin with rounded corners, or a 'circular' wash basin should be installed so that a wheelchair user can still approach the toilet pan from the front or the pan may be used by a commode.

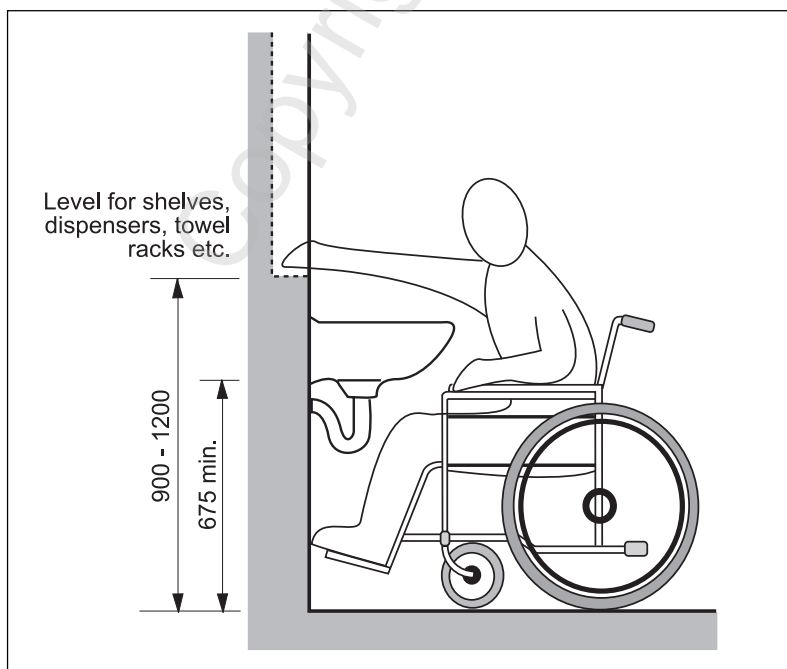

Figure 30 – Location and clearances for washbasins and fittings

10.5.9 Grab rails

Grab rails shall meet the requirements of Appendix F.

10.5.9.1 Location

Pull rails and grab rails shall be installed as shown in figure 28, on doors and figure 31, in toilets.

10.5.10 Toilet facility fittings

Toilet facilities shall include the amenities and fittings required in this Standard.

10.5.10.1 Design

Fittings shall be simple and operable with one hand.

10.5.10.2 Position

The provision of fixed grab rails, toilet paper holders etc. shall be in accordance with figure 31. In addition:

- The toilet paper dispenser and waste sanitary napkin receptacles shall be located within easy reach of a person using the toilet pan;
- Soap dispensers, sanitary towel disposal units, hand-dryers etc. shall be installed at a height between 900 mm and 1200 mm above the finished floor level but shall not encroach into the wheelchair manoeuvring space;
- If a mirror is provided, the lower edge shall be not more than 1000 mm above the finished floor level.

10.5.10.3 Visibility

All fittings shall contrast visually to their background.

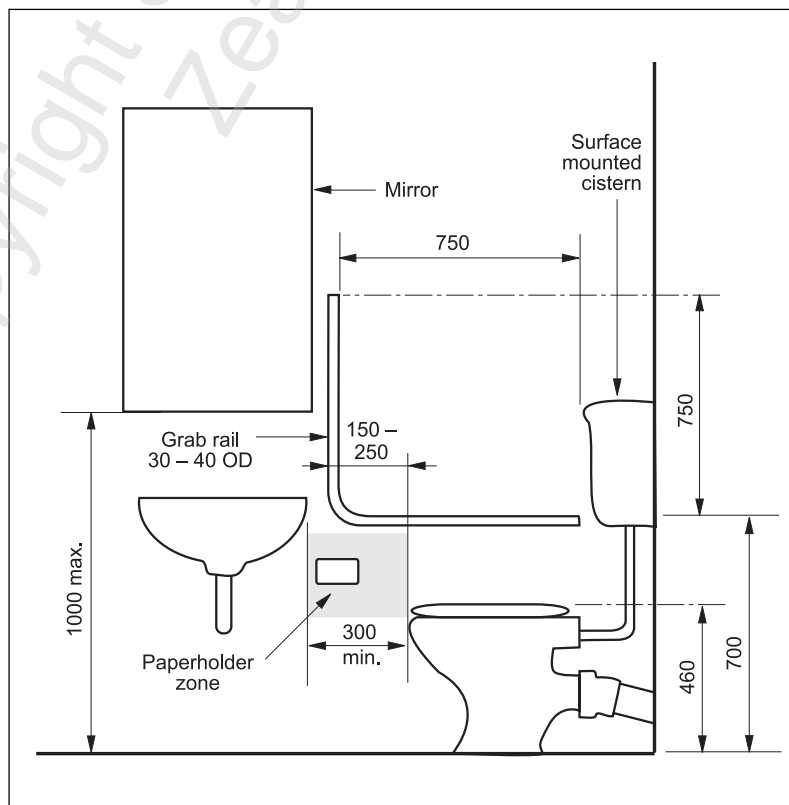

Figure 31 – Toilet unit fittings – positioning of grab rail and paper roll holder

10.5.11 Showers

Where showers are required for staff or public use, a wet-area shower shall be provided for people with disabilities. If two or more shower cubicles are provided, at least one shall have a seat and controls for the opposite hand.

Accessible shower cubicles may be complete in themselves or be part of a combined accessible toilet/shower facility.

10.5.11.1 Size

The minimum area for a shower unit and drying space is shown in figure 33.

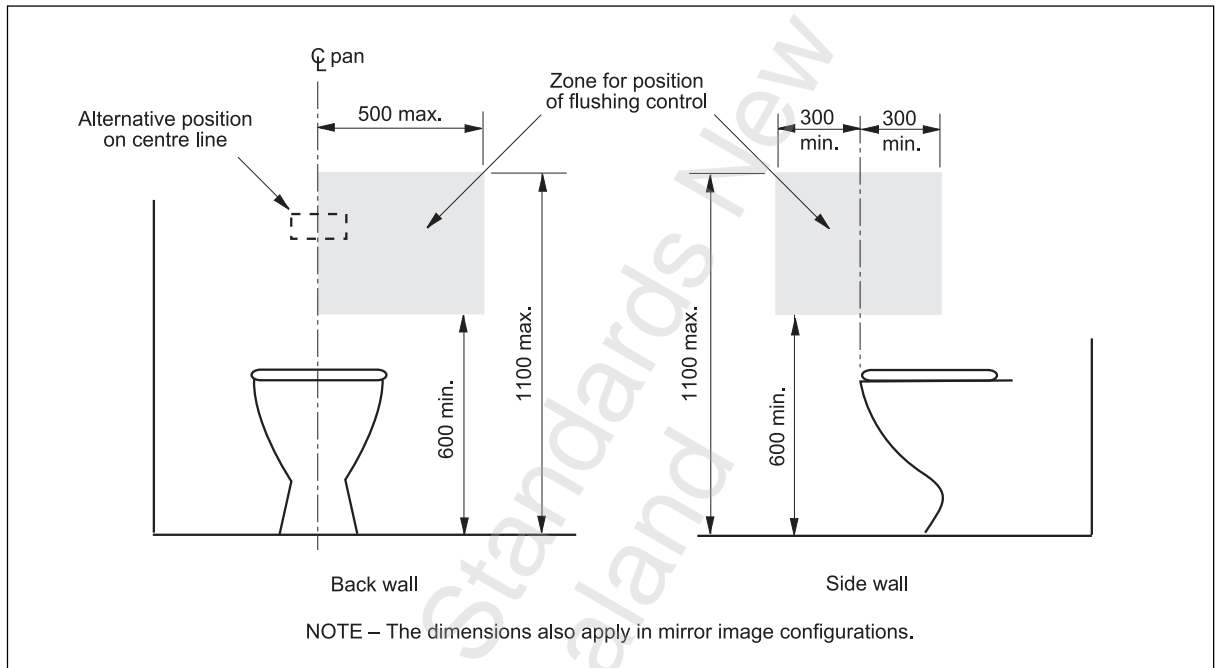

Figure 32 – Toilet unit fittings – zone for position of flushing control

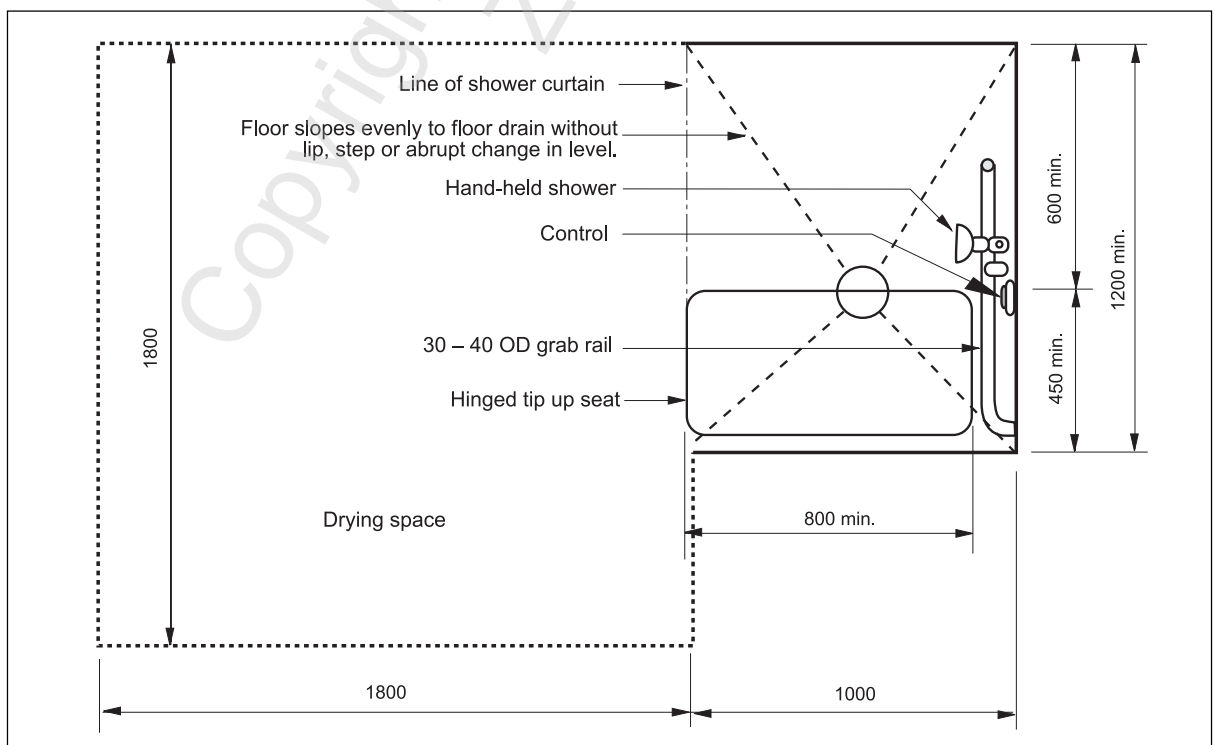

Figure 33 – Minimum space required for a single shower unit

C10.5.11.3

As shown in figure 35, the area for the wet area shower also serves as the space beside the toilet pan for side transfer to the pan.

C10.5.11.3(c)

A grille running inside the wet area is an effective way of reducing spread of water. However, this should not be necessary if the floor area has been properly installed and slopes evenly to floor drain.

C10.5.11.4

A flexible, adjustable hand-held shower hose enables control of the direction of water flow by people of different heights and abilities and allows somebody to assist the user.

10.5.11.2 Design

If the drying space is used for dressing and undressing it shall be separated from the shower.

Walls and partitions enclosing a shower and less than 1800 mm high shall be sufficiently robust to resist the impact of a falling body and shall be of sufficient strength to carry grab rails, refer to Appendix F.

10.5.11.3 Floor

The floor shall:

- (a) Be continuous with that of the shower;
- (b) Have a fall of no less than 1:50 toward the waste situated toward the corner made by the walls, see figure 35. All floor surfaces inside the shower cubicle shall be impervious and slip resistant.
- (c) Have any drainage provided between the shower and drying space, or the provision of a floor-level guide for moveable doors, partitions or shower curtain, flush with the floor.

10.5.11.4 Fittings

Shower cubicles shall have:

- (a) Grab rails, soap holders, and shower controls and fittings fixed in accordance with figure 34;
- (b) A hand-held showerhead attached to a flexible hose installed to enable the user to shower while sitting or standing;
- (c) A fitting shall be provided to allow the showerhead to be attached at various angles and heights between 1000 mm and 1900 mm above the finished floor level (see figure 34);
A combined slide rail/grab rail satisfying the requirements of Appendix F5, F6 and F7 may be acceptable.
- (d) A lever operated mixer shall be provided;
- (e) A water supply where the hot water has a maximum temperature of 55 °C, refer to NZBC G12/AS1;
- (f) A self-draining, slip resistant seat, 800 mm x 450 mm minimum, provided inside the shower cubicle at a height between 450 mm and 550 mm above the finished floor level. This seat shall be securely fixed to the wall and shall be hinged so that it swings or folds out of the way;
- (g) A clothes hanging device shall be fitted, positioned between 1200 mm and 1350 mm above the finished floor level in drying spaces.

These fittings shall be arranged as shown in figure 34:

10.5.12 Combined toilet and shower

Where toilet, hand basin, and shower are combined they shall be provided in accordance with figure 35.

10.5.13 Baths

Baths and combination bath/showers shall not be used as an alternative to showers, but may be provided in addition.

Figure 34 – Shower cubicle fittings

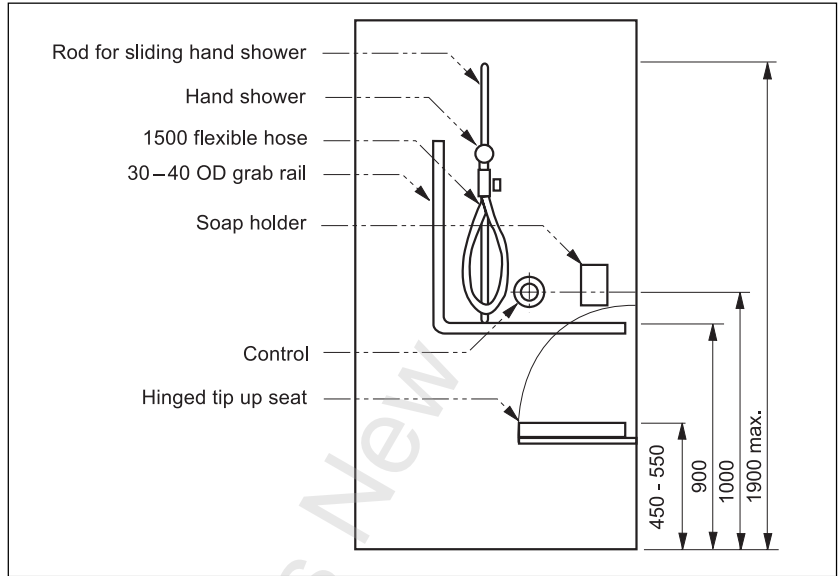
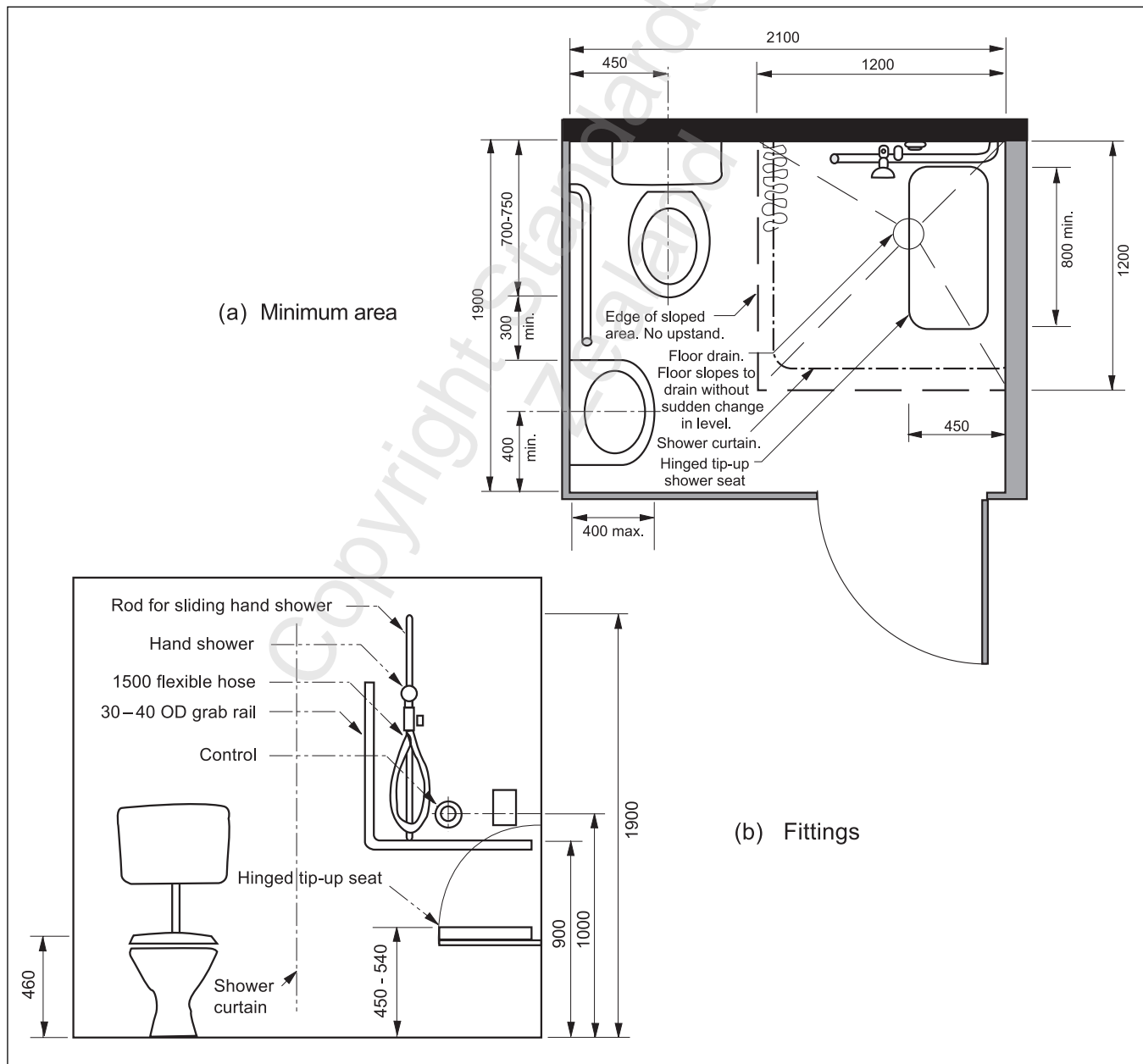

Figure 35 – Combined toilet and shower



C11.1.1

Requirements for reception counters and desks need to ensure that people with disabilities are able to carry out the normal processes and activities expected at that counter or desk.

C11.1.3

Where security is a requirement, consideration should be given to the innovative use of step-down counters, security grilles or toughened glass.

11 PUBLIC FACILITIES**11.1 Public counters and desks****11.1.1 General**

Reception counters and desks for public use on an accessible route shall have at least one space for use by people in wheelchairs as visitors and staff working in the reception area (see figure 36). Such a space shall be at least 900 mm wide.

11.1.2 Other forms of counters and desks

Additional examples of public counters such as in public bars, shops, supermarket checkouts shall comply with 11.1.1 as shown in figure 37.

11.1.3 Screens

Wholly transparent screens on counter tops shall be provided with a clearly visible contrast strip.

11.2 Telephones**11.2.1 General**

Accessible telephones shall be on an accessible route.

11.2.2 Clear floor or ground space

Whether located on the street or in a foyer of a building the approach to an accessible telephone shall be free of obstacles. It shall:

- (a) Have a clear floor or ground space of at least 1200 mm by 1200 mm that will allow either a forward or parallel approach by a person using a wheelchair;
- (b) Not be restricted by stepped bases, enclosures, and fixed seats.

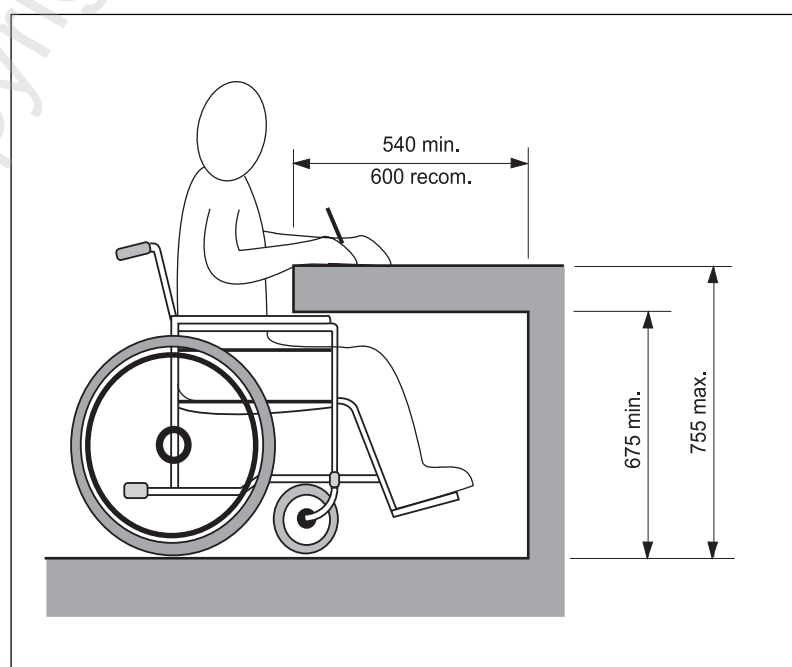

Figure 36 – Public counters and desks

11.2.3 Design

The design shall provide a user with privacy and accessibility:

- (a) An enclosed booth must have a door, which opens outwards;
- (b) The parts of the telephone that are essential to its basic operation shall not be higher than 1200 mm above the ground or floor;
- (c) Accessible telephones shall be equipped with a minimum handset cord length of 750 mm;
- (d) Accessible telephones should have push button controls whenever possible;
- (e) Telephone directories, if provided, should be in a position that is convenient for use by a wheelchair user;
- (f) Shelving shall be set at 775 mm minimum above the ground or floor; and
- (g) Open cubicles shall be 540 mm minimum deep.

C11.2.3

In an enclosed booth space for manoeuvring a wheelchair can be increased by providing 150 mm clear under space around base of walls.

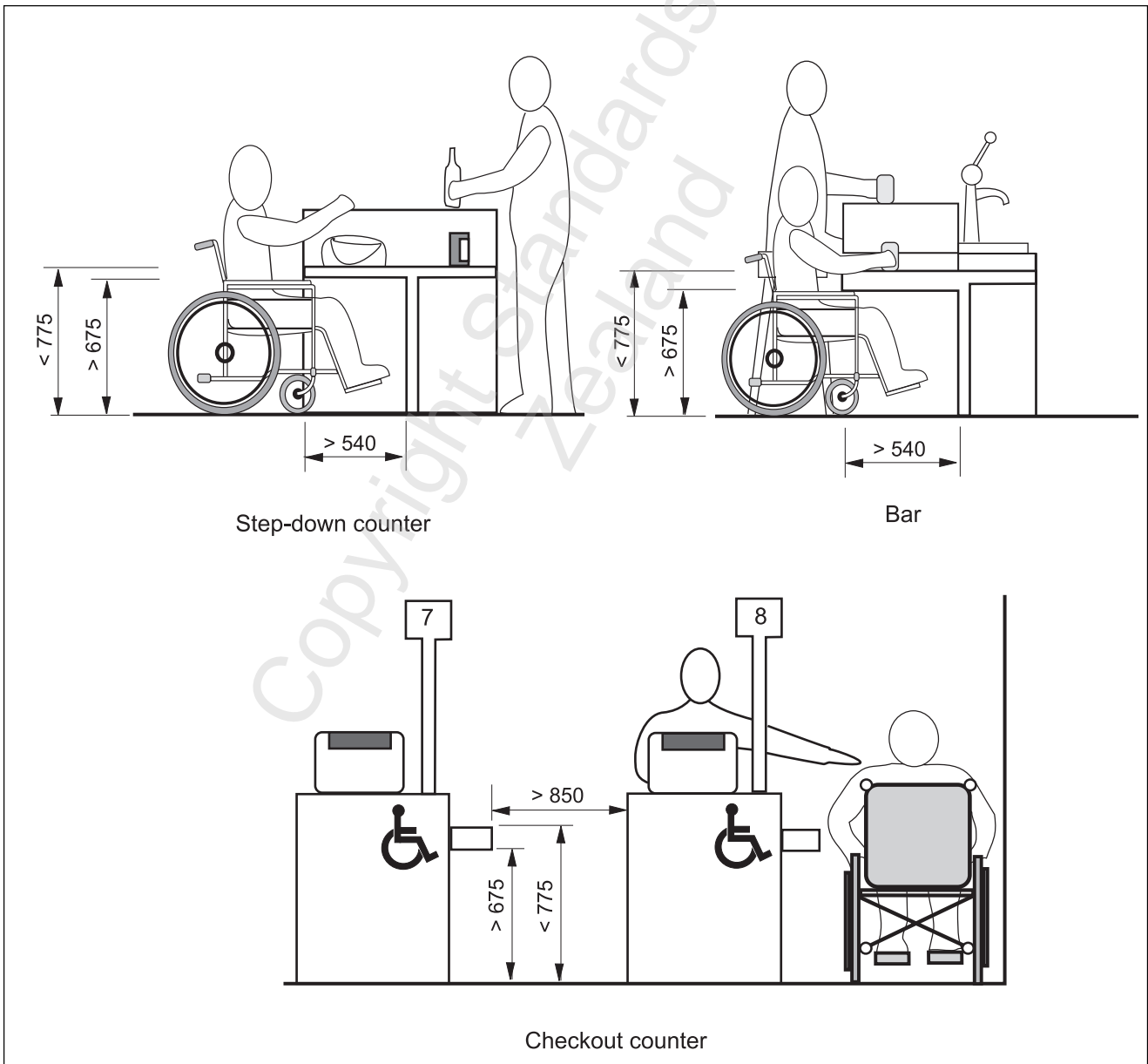

Figure 37 – Public counters

C11.2.5

Telephones for people with a hearing impairment are not commonly found in public areas in New Zealand but they are available. Such equipment is usually of specialised design. Several techniques are used to aid people with hearing impairment such as receivers that generates a magnetic field in the area of the receiver cap, TTY systems, volume controlled telephones and bone-conductance telephones.

11.2.4 Detection by people with visual impairment

Accessible telephone booths or stands shall have:

- Part of the structure within 150 mm of the ground that will be detectable by a cane user;
- Colour contrast to the surroundings.

11.2.5 Accessible equipment for people with a hearing impairment

If a telecommunications device for the deaf is provided, the location of such equipment shall be indicated by strategically placed signage. For examples of accepted signage see figure 38.

11.3 Automatic tellers, vending machines

Automatic tellers, vending machines etc. shall comply with the principles of approachability, accessibility required and usability as described for the use of telephone controls (refer 11.2). Figure 39, shows examples of dimensions for height of automatic teller and vending machine.

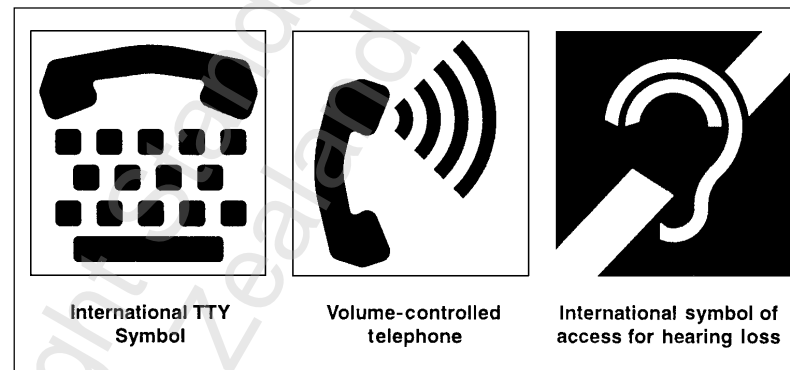

Figure 38 – International symbols for people with hearing impairment

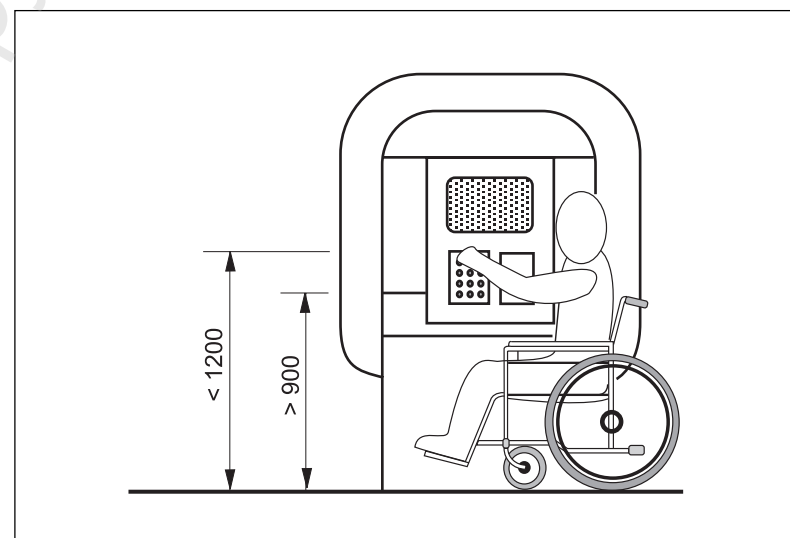

Figure 39 – Automatic teller or vending machine

11.3.1 Keypads and keyboards

Accessible keypads and keyboards shall:

- (a) Have privacy of use;
- (b) Have key surfaces that are raised from the base and separated from each other;
- (c) Have key surfaces recommended at least 1 mm above the base and with a separation of at least 3 mm between keys;
- (d) Have a logical and consistent arrangement of numbers and letters;
- (e) Have colour contrast for the keypads;
- (f) Preferably have telephone pad arrangement used for numbers and the typewriter arrangement for letters;
- (g) Have clearly identified special function keys, and
- (h) Have a single raised dot or braille marking on the number 5 key.

11.3.2 Information display

To be accessible the information display shall:

- (a) Be situated at a height so that it can be easily read by a person in a wheelchair (see figure 5);
- (b) Be protected from reflected glare or shall be angled from the vertical to prevent reflected glare (refer to 5.10);
- (c) Use lettering that is visible to a person with normal sight from a point 1000 mm in front of the screen;
- (d) Use plain characters, 5 mm high, which contrast well with the background.

12 PLACES OF ASSEMBLY, ENTERTAINMENT AND RECREATION

12.1 General

Provision shall be made to accommodate people with disabilities in rooms and areas used for meetings, entertainment, assembly and recreation. In all cases this provision shall be on an accessible route.

12.2 Places of assembly and entertainment

People with disabilities shall be able to be seated as part of an audience. They shall be able to speak, lecture or entertain an audience from the main stage of a place of assembly or entertainment and have access to all backstage facilities including performers changing areas, toilet shower facilities and the green room.

12.2.1 Part of an audience

12.2.1.1 Number of wheelchair spaces

The number of spaces provided shall be as follows:

- (a) 1 – 250 people: not less than two spaces;
- (b) For every 250 people or part thereof extra, add one space.

12.2.1.2 Location of wheelchair spaces

In all cases the spaces reserved for wheelchair users shall be:

- (a) Adjacent to and included in normal seating provisions (see figure 40);
- (b) Spread as evenly as possible throughout the area;
- (c) Of adequate size to allow for wheelchair manoeuvrability;
- (d) On level ground and floor surfaces.

12.2.2 Listening systems

Where a sound amplification system is provided, a listening system shall be installed to cover the total area of the room. Guidance on listening systems is found in Appendix H.

12.2.2.1 Usability

The recommended design sound levels for various functional areas of buildings given in AS/NZS 2107 shall be adhered to, for effective hearing.

12.2.2.2 Signs

A sign indicating that a listening system is installed or is available shall be provided in accordance with 4.8 at the main door or doors to the enclosed space. Where the listening system does not cover the total area of the enclosed space, such signs shall designate the boundaries of the area served.

C12.2.1.2

An example of how wheelchairs can be located adjacent to normal seating is shown in figure 40. This also shows a grandstand seating arrangement.

C12.2.2.1

Care shall be taken to comply with these recommendations in the installation of air-conditioners, computer machinery etc. In order to hear effectively when background noise is present the recommended signal-to-noise ratio is 15 dB minimum.

12.2.3 As a speaker or performer

Ramp access shall be provided to podium or stage areas. Accessible facilities shall also be provided for artists, including changing areas, toilets, showers, and the green room. An accessible route shall be available from these facilities to the audience area.

12.3 Places of recreation

People with disabilities shall be able to access and use all parts of a recreation facility in accordance with the requirements of this Standard.

12.3.1 Swimming pools**12.3.1.1 Accessibility of facilities**

Accessible toilets, showers and changing rooms designed using the principles of this standard shall be provided on an accessible route.

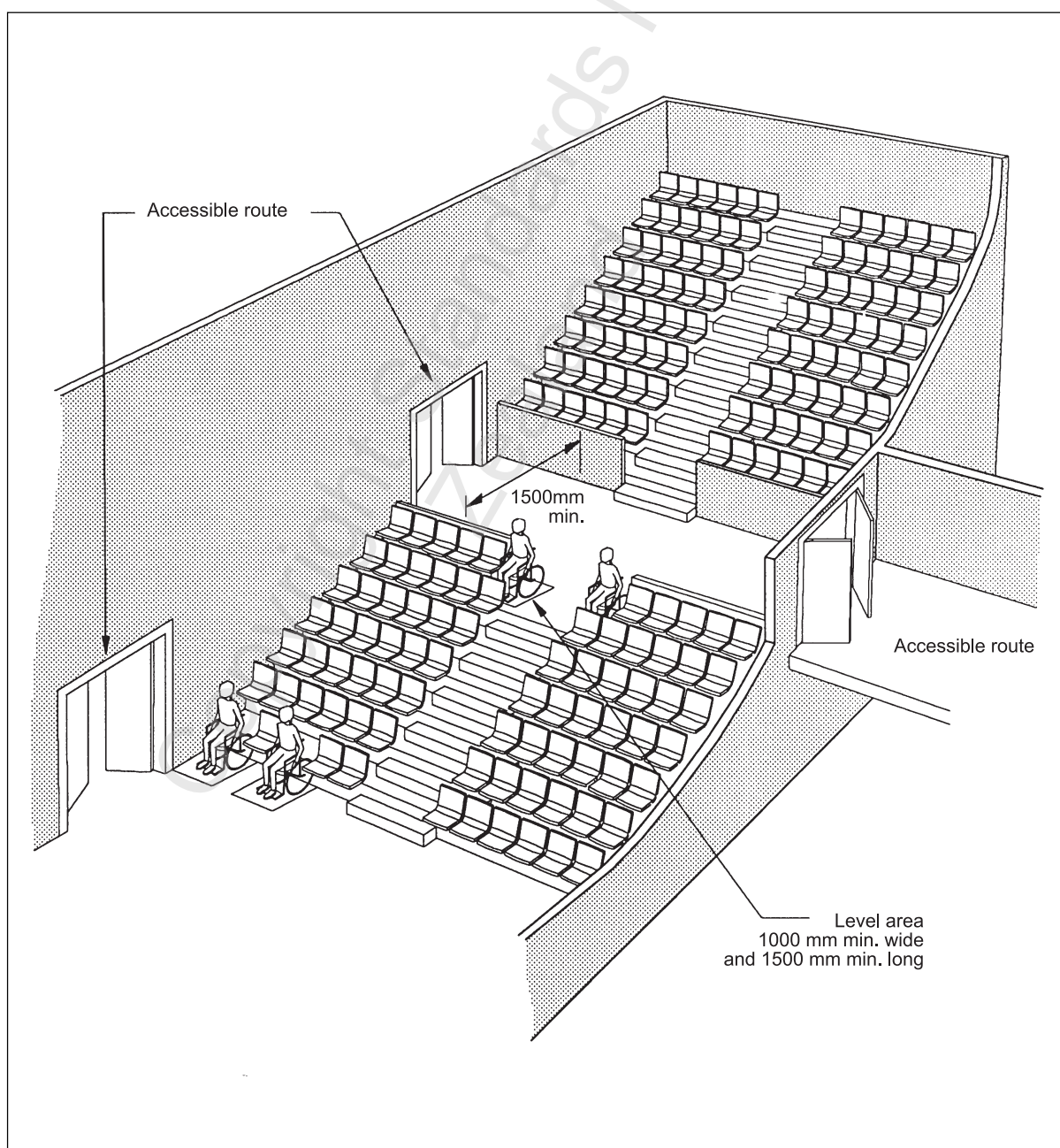

Figure 40 – Places of assembly – Examples of seating arrangements

C12.3.1.2

A ramp that leads from the poolside into the pool is the preferred means of access to the water. A slope of 1:12 down to a water depth of 1200 mm is acceptable.

12.3.1.2 Access to the pool

The swimming pool shall be available from an accessible route and unaided access to the water shall be possible from the poolside.

12.3.2 Sports track and field activities**12.3.2.1 Accessible facilities**

Accessible toilets and showers and changing rooms using the design principles in this standard shall be provided on an accessible route.

12.3.2.2 Access to the sports track or field

Sports tracks and fields shall be accessible via an accessible route.

Copyright Standards New Zealand

13 ACCESSIBLE OUTDOOR PUBLIC AREAS

13.1 General

For urban areas to be accessible to people with disabilities, territorial local authorities and town planners etc. shall have regard for the construction and siting of footpaths and the servicing of the area by public transport. See Appendix A, A4 and A5.

13.1.1 Accessways

All accessways shall be at least 1200 mm wide, have a maximum crossfall of 1 in 50 and shall as nearly as is reasonably practicable conform to the requirements of an accessible route (refer to section 4 and Appendix D. Many footpaths act as accessways.

13.1.2 Public transport

Whenever possible, public transport drop-off points shall be situated on accessways and shall be as close as practicable to accessible routes and to the main entrances of buildings of major public importance.

13.2 Outdoor hazards

13.2.1 General

For an accessway to be usable by people with disabilities it shall be free from hazards or obstructions. Where hazards or obstructions are permanent there shall be a designed arrangement e.g. tactile surface, which will guide the accessway user around the obstruction or steer them to the other side of the accessway (see figures 41 and 42). Movable obstructions like tables and chairs shall be placed and controlled so as to leave a clear route.

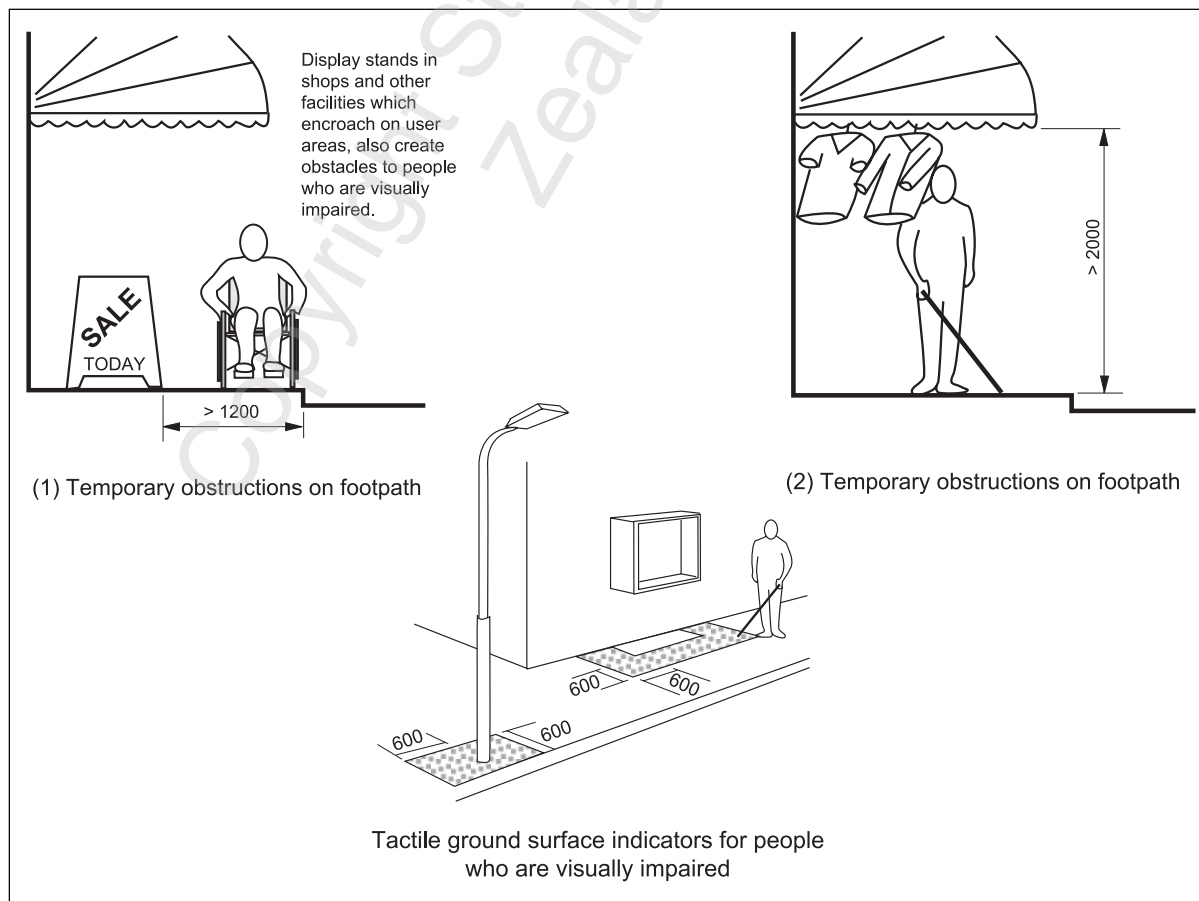

Figure 41 – Outdoor hazards

13.2.2 Overhead obstructions

Hanging signs, lights, awnings, and similar objects shall have a minimum clearance of 2000 mm above the ground or finished floor level of the accessible route, accessway or usable area (see figure 41).

13.2.3 Permanent and temporary obstructions

Objects fixed permanently to the ground or to the side of an accessway e.g. telephone booths or outdoor furniture, including temporary obstructions such as display stands, billboards, sandwich boards etc. shall:

- (a) Not intrude into or obstruct the 1200 mm clear accessway;
- (b) Have a feature within 150 mm of the ground that will be detectable by a person using a white cane;
- (c) Be colour contrasted to the surroundings.

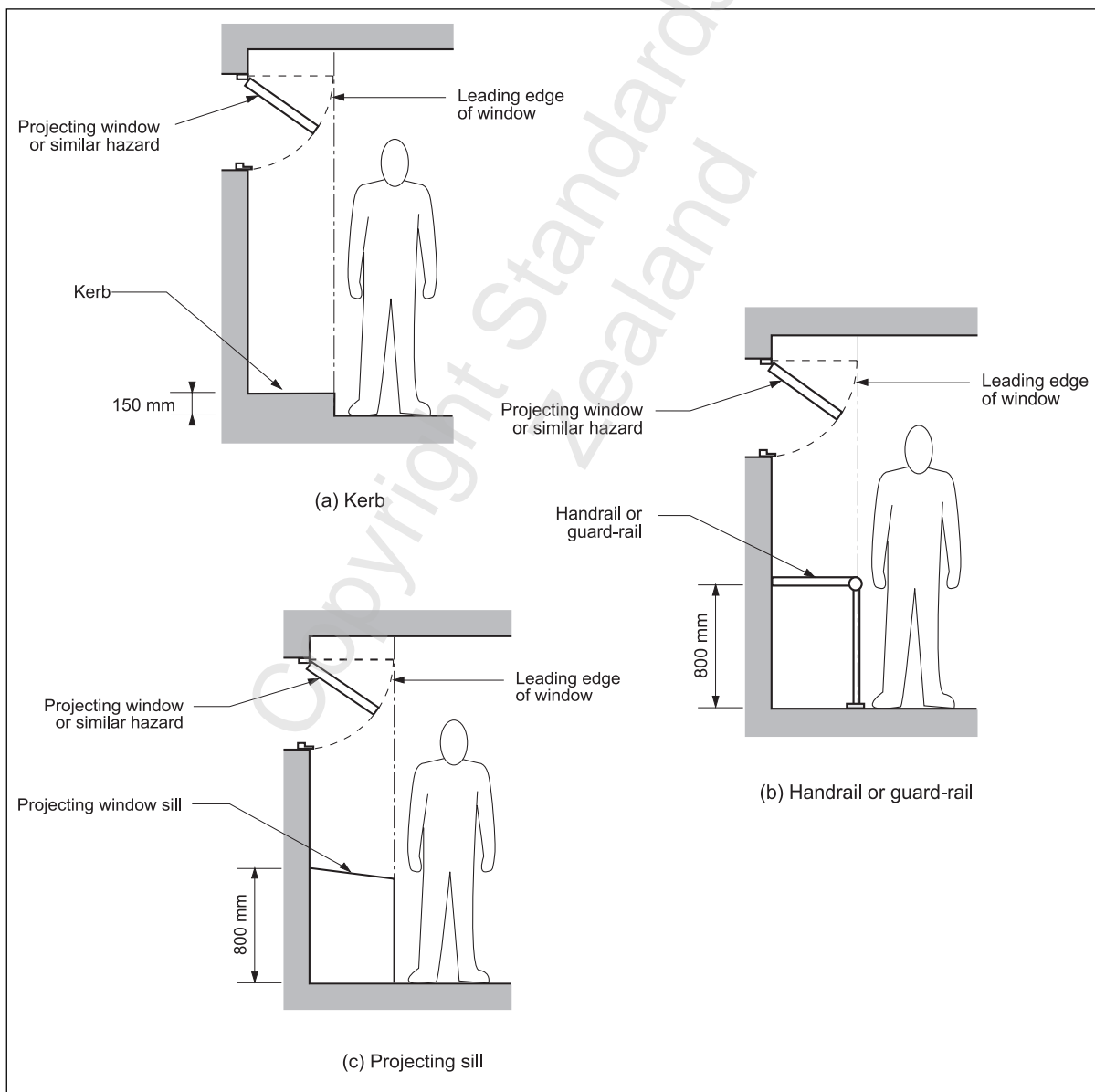

Figure 42 – Protection from dangerous projections

13.2.4 Windows

Windows or doors shall not open across a footpath, corridor, stair, or ramp so that they obstruct access, unless this is unavoidable, e.g. for emergency exits to buildings.

13.2.5 Bollards

Openings between bollards and similar barriers to non-pedestrian traffic shall be positioned or constructed to allow for the passage of wheelchairs (see figure 43).

C13.2.5

Landscape lighting may be incorporated into bollards, as they become particularly hazardous at twilight.

13.3 Kerb design

13.3.1 General

Kerbs and channels/gutters shall be designed to allow a wheelchair or person with a walking aid to safely and easily negotiate the transition between two surfaces, see figures 44 and 46.

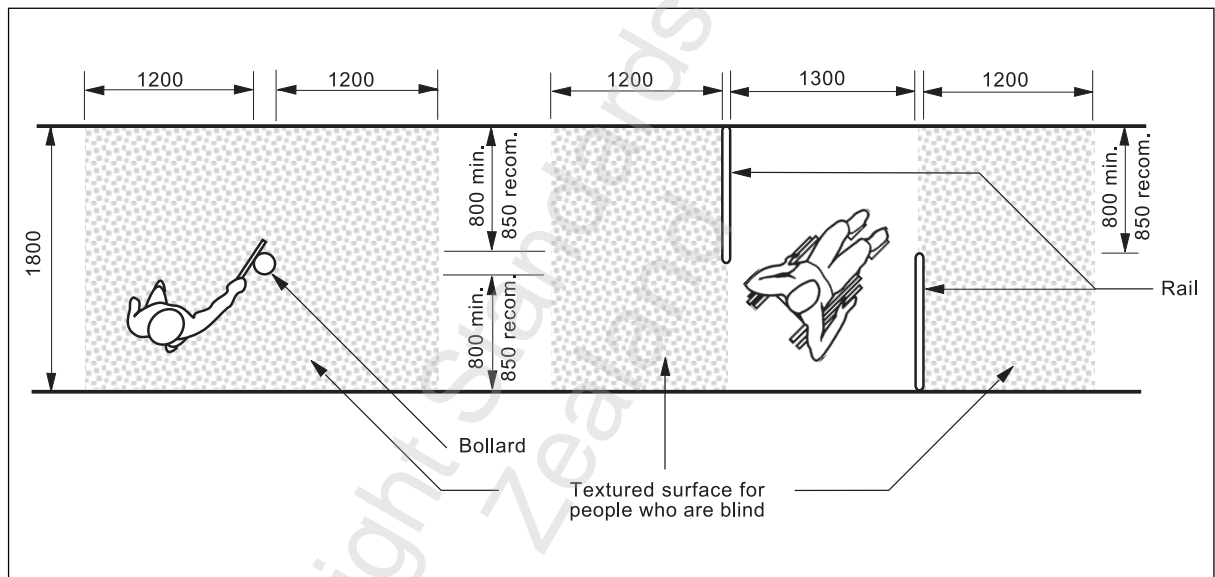

Figure 43 – Space required between bollards, etc.

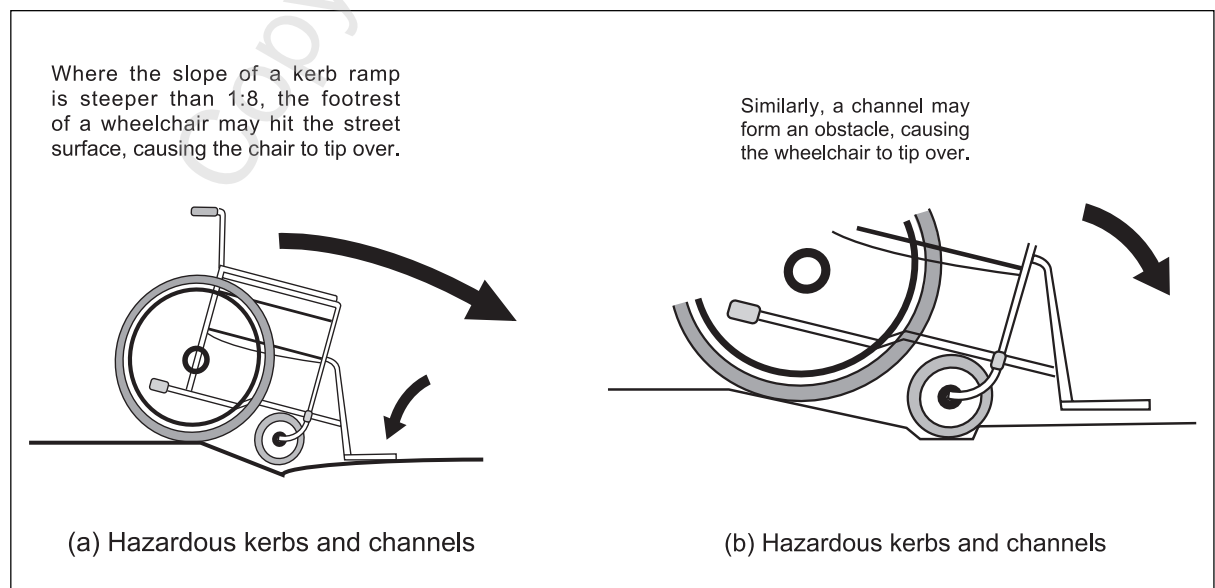

Figure 44 – Kerb and channel design

13.4 Kerb ramps

13.4.1 Local authorities

When the territorial authority forms or constructs or makes permanent improvements to footpaths and kerbs, the kerb ramp shall comply with this section of this Standard, refer also to Appendix A, A4.1.

There will be situations where the local geography will not allow a standard kerb ramp to be provided. Other solutions that provide reasonable and adequate access, may be approved by the Council provided the principles of location 13.4.2, design 13.4.3 and surface finish 13.4.4, have been applied to the alternative designs.

13.4.2 Location

13.4.2.1 General

Kerb ramps shall be:

- Located so that users have an unobstructed view of traffic approaching from any direction;
- Provided at pedestrian crossings;
- Provided where footpaths cross a kerb at road intersections.

13.4.2.2 Location of ramps

13.4.2.2.1 Offset ramps

The kerb ramp shall be offset from the intersection corner to line-up with the direction of travel, see figure 45(a).

13.4.2.2.2 Corner ramp

Where the ramp cannot be offset from the corner, or where an intersection allows pedestrian traffic to cross the road at any angle the kerb ramp shall be graded and carried around the quadrant, refer to figure 45(b).

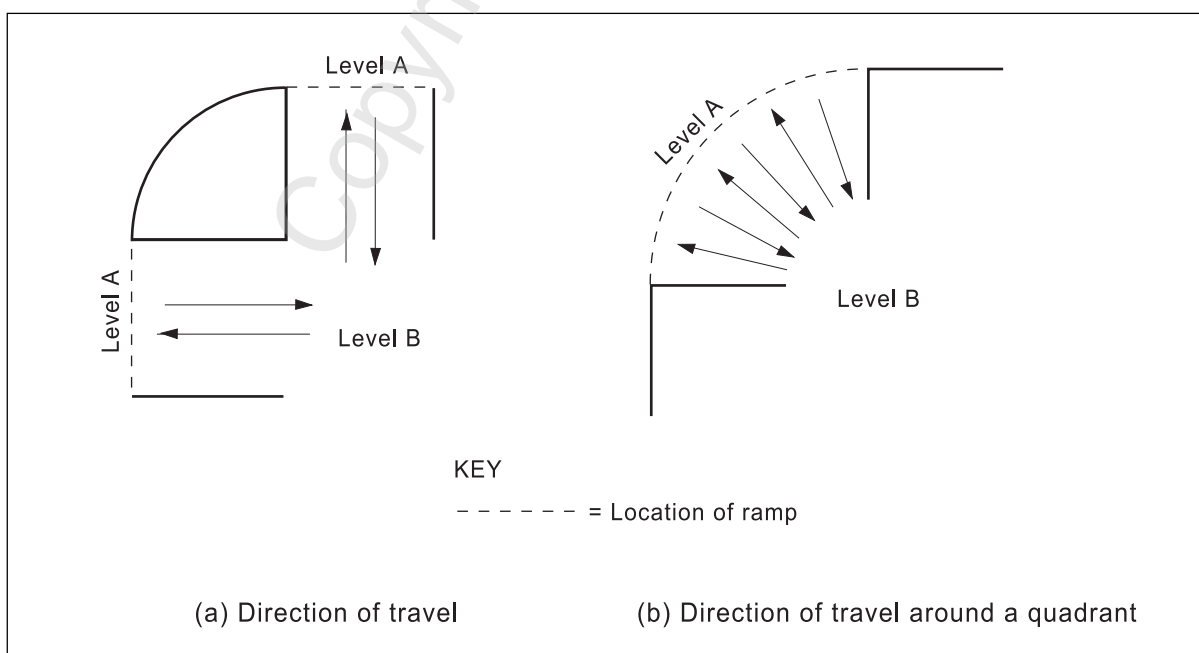

Figure 45 – Location of kerb ramps or step ramps

13.4.3 Design

13.4.3.1 Construction

The ramp shall be constructed as shown in figure 46. It shall have:

- (a) A gradient not steeper than 1 in 8;
- (b) A maximum length of 1500 mm;
- (c) No variation of slope from side to side;

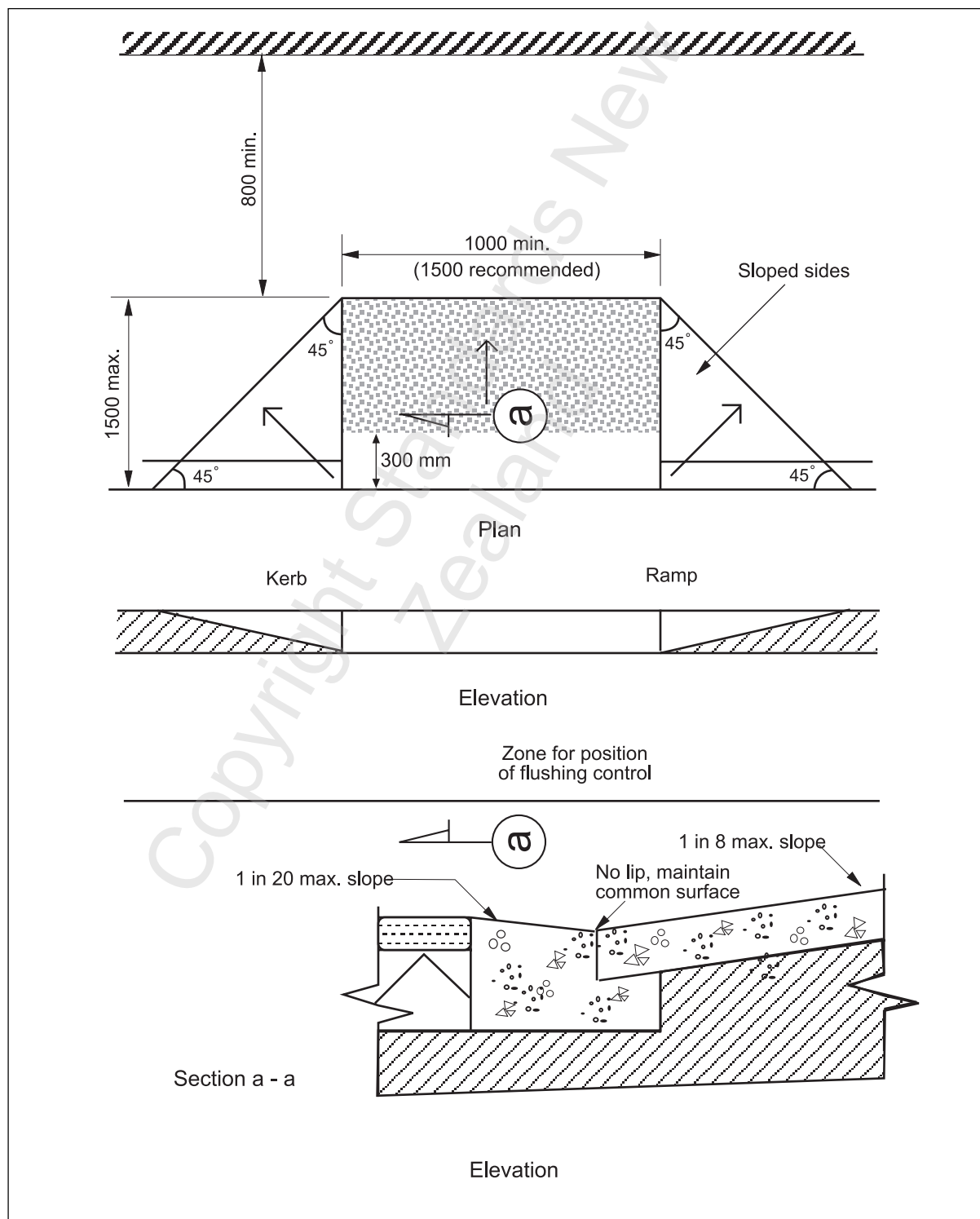

Figure 46 – Kerb ramps

C13.4.3.1(d)

Invariably the junction between a road or gutter surface and a kerb ramp slopes downward to a point at the kerb edge of the gutter. In this situation any upstand i.e. vertical difference in height, between ramp and gutter, becomes very difficult for a wheelchair to negotiate (also see figure 44).

C13.4.3.1(h)

The recommended width of 1500 mm allows most wheelchairs or prams and wheelchairs to pass each other in different directions (see figure D10).

C13.4.4

The slip resistant finish could take the form of rough brooming or similar texture.

C13.4.5.1

The alignment cue could be the use of landscaping or tactile surfaces.

- (d) No upstand between channel/gutter and ramp;
- (e) A change in surface texture to delineate the common surface at the bottom of the ramp between kerb line and road edge gutter. Tactile ground surface indicators are recommended to best perform this function (refer to 13.4.5.2);
- (f) A maximum camber or crossfall on either the road or footpath leading to the ramp, of 1 in 20;
- (g) A minimum of 800 mm of space between the top of the ramp and any obstruction.
- (h) A minimum width of 1000 mm.

13.4.4 Surface finish

A kerb ramp shall have a slip resistant finish, contrasting in both colour and texture with the adjacent footpath and road as shown in figure 47.

13.4.5 Alignment cues**13.4.5.1 General**

An accurate alignment cue shall be provided to aid a person who is blind or has vision impairment before setting off from the kerb ramp.

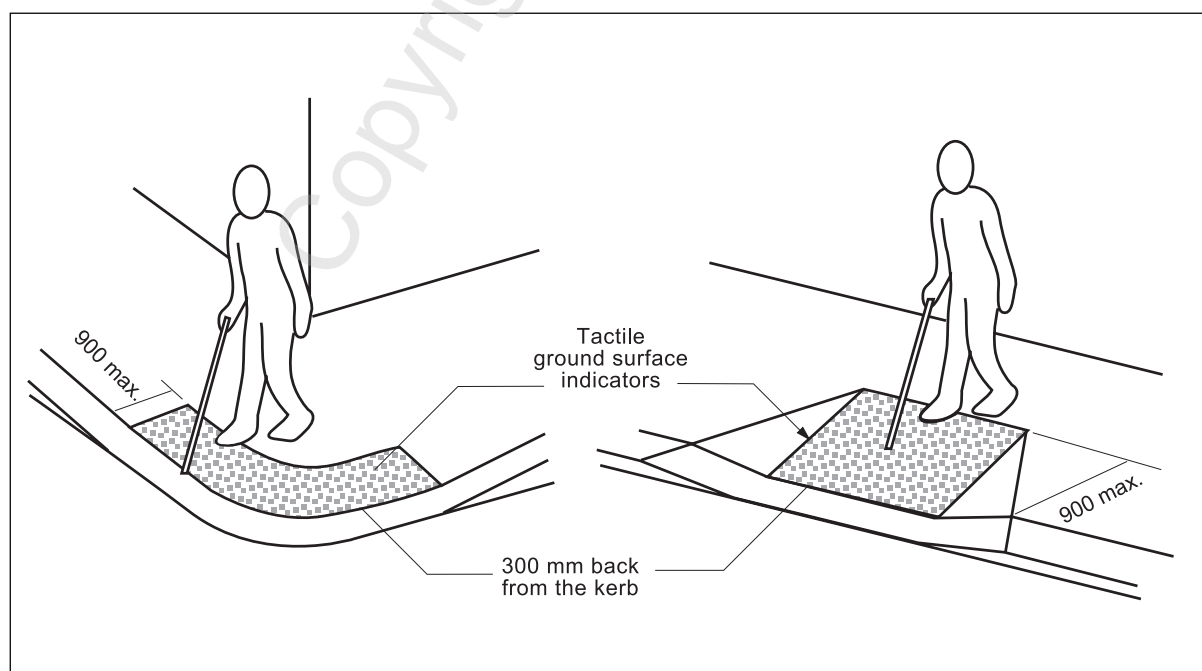

Figure 47 – Tactile ground surface indicators at kerb ramps

13.4.5.2 Tactile ground surface indicators

A tactile change of surface, whether of concrete or other slip resistant material, shall be used to indicate the full width of the ramp and extended for the full face of the ramp. Such a change in texture should be set on the ramp 300 mm up from the common surface between the kerb line and road edge gutter (see figures 46 and 47).

13.4.5.3 Road crossings

Wide road crossings, which are part of accessible routes, shall be provided with alignment cues to aid the blind or people with vision impairment (see figure 48).

C13.4.5.2

The tactile change of surface and the remaining surface of the ramp aid orientation for people with a visual impairment. AS 1428.4 describes some types of tactile surface indicators. It is important that any raised or domed portion of a tactile ground surface indicator does not obstruct the passage of the small front wheels of wheelchairs. Further research is required to establish maximum diameter and height for raised or domed portion and minimum gap between these portions.

C13.4.5.3

Alignment cues could take the form of:

- (a) *Off-setting the kerb ramp and crossing from the building edge in the direction of travel (see figure 48). This prevents visually impaired people from continuing straight ahead and unwittingly entering the crossing;*
- (b) *Median refuges;*
- (c) *Raised cues, thermoplastic lines or similar markings to define crossing direction;*
- (d) *Change in surface finish on road through use of pavers or similar contrasting texture change;*
- (e) *Tactile ground surface indicators.*

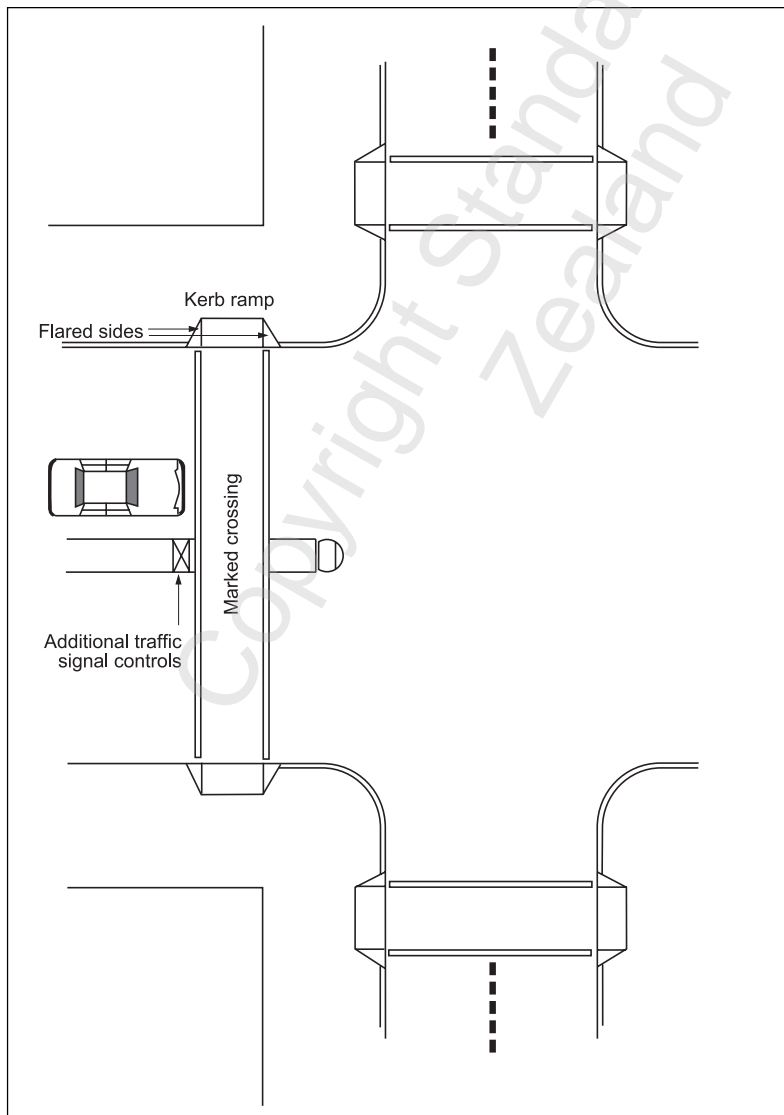

Figure 48 – Road crossings

C13.5.1

In pedestrian malls and similar places, all street furniture shall be positioned clear of the accessible path of travel (see figure 49).

13.4.6 Audible traffic signals

Whenever an audible traffic signal is installed it shall have:

- (a) An audible locating signal;
- (b) An audible crossing signal; and
- (c) A tactile 'cross signal' which clearly indicates the pedestrian "cross" and "wait" phases.

The audible traffic signal system and installation shall comply with Section 5 of RTS14, published by the Land Transport Safety Authority.

13.5 Street furniture**13.5.1 General**

Street furniture, which includes objects such as seats, tables, drinking fountains, planter boxes, rubbish bins and the like, shall comply with the following:

- (a) Objects shall not protrude into an accessible path of travel. Seats shall be a minimum of 500 mm away from the path of travel;
- (b) Objects shall be of a colour that provides a contrast with their background and have a luminance factor of not less than 0.3 (30 %).

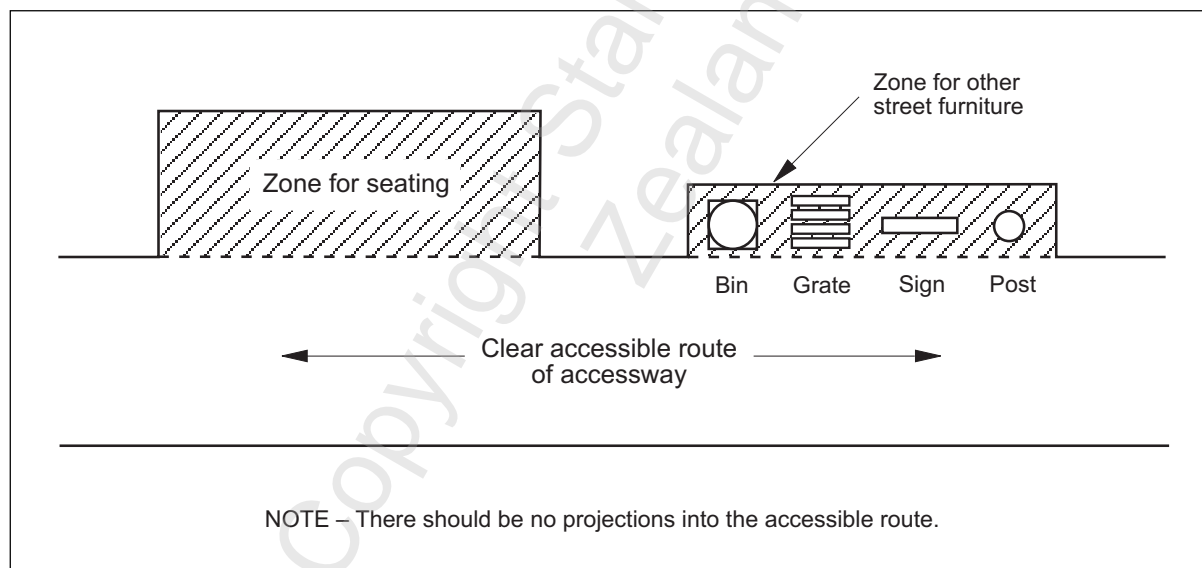

Figure 49 – Example of position of street furniture

13.5.2 Seating in pedestrian areas

The design and installation of seating shall be as follows:

- (a) The front of the seat shall have a clear space between any legs at ground level to within 150 mm of the front edge of the seat, and to within 100 mm of the seat height to allow for rearward adjustment of feet when rising (see figure 50);
- (b) Where armrests are provided, the top surface of the armrests shall be at a height of 260 ±40 mm above the seat.

13.5.3 Car parks

13.5.3.1 Signs

Figure 4 shows the preferred wording for signs in public parking buildings and public streets monitored by parking wardens.

13.5.3.2 Car park size

The provisions of 5.5 of this Standard apply.

13.5.3.3 Surface

The provisions of 5.6 of this Standard apply.

C13.5.2

- (a) Seats should generally be 450 mm high but where a high proportion of elderly users are anticipated, heights up to 520 mm are preferred. Children and small people may prefer seats as low as 350 mm high. Where possible, a range of seat heights should be provided;
- (b) A typical park bench is shown in figure 50;
- (c) For outdoor tables, see Clause 24, AS 1428.2;
- (d) Armrests should be provided for all seats;
- (e) The front edge of the seat shall have a minimum radius of 30 mm;
- (f) No edge or projection shall have a radius of less than 5 mm unless protected from contact with the user;
- (g) The seat shall drain free of water.

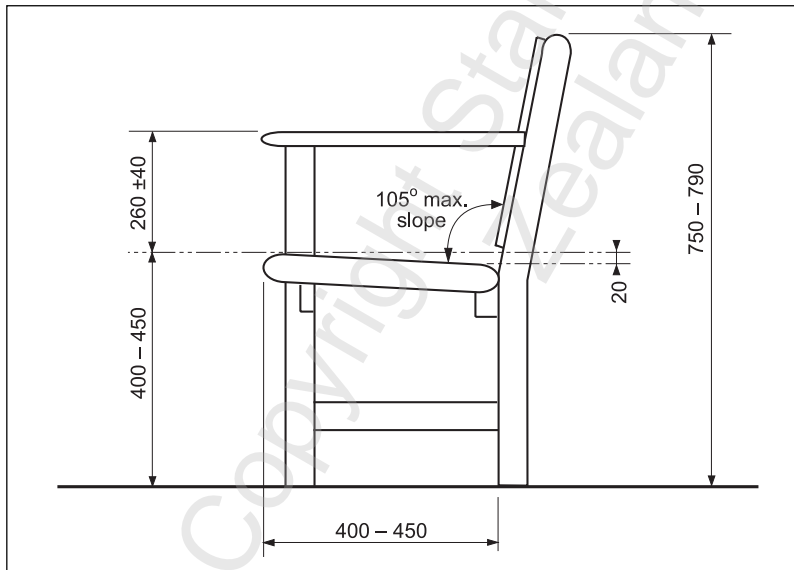

Figure 50 – Typical park bench seating

14 ACCESSIBLE ACCOMMODATION

14.1 Scope

This section covers accommodation for people with disabilities. Some of the topics go beyond the requirements of the New Zealand Building Code, refer to 1.4.5.1. The information also has application for the design of private dwellings for people with disabilities.

14.2 Application

The type of accommodation to which this section applies is defined in section 47A(4)(j) of the Building Act 1991 as: Hotels, motels, hostels, halls of residence, holiday cabins, groups of pensioner flats, boarding houses, guest houses, and other premises providing accommodation to the public. Section 4(k) also identifies old people's homes.

14.3 General

Accommodation that is intended to be used by people with disabilities shall be built and fitted-out in a manner that meets their needs and in compliance with the minimum requirements of this Standard.

14.4 Access

Accessible accommodation shall be on an accessible route.

14.4.1 Lifts

Lifts are not required in two and three storey hotels and motels provided that the accessible accommodation units, reception office, restaurant, bars and other communal facilities are on the ground floor.

14.5 Accessible accommodation units

14.5.1 Accommodation units

Under this Standard:

- (a) In motels each self-contained unit is an accommodation unit;
- (b) In a hotel, each room or suite of rooms that is intended for one person or family is an accommodation unit;
- (c) In dormitory accommodation where each bedroom holds 4 – 6 people, then each bedroom is an accommodation unit.

14.5.2 Number of accessible accommodation units

The minimum number of accessible accommodation units shall comply with table 2.

Table 2 – Number of accessible units

Total number of accommodation units or total number of cabins, tent sites or caravan parks	Number of accessible accommodation units
1 – 10	1
11 – 25	2
For every 25 units thereafter	Add 1 unit

C14.5.1

In open communal accommodation with no discrete units, it is suggested that every 4 – 6 people constitute a 'unit', and accessible toilet/shower/washing facilities are provided according to table 2.

14.6 Arrival and departure

14.6.1 Car parks

A clearly marked reserved accessible parking space at the main accessible entrance shall be provided to assist the process of booking in and booking out.

14.6.2 Reception

Hotel and motel patrons with disabilities shall be able to register and book out at reception with the same convenience as the other guests and the counter shall be usable by people with disabilities (refer to 11.1).

14.6.3 Public and guest areas

The public reception area shall be on an accessible route.

There shall be no internal steps on the accessible route.

14.6.4 Telephones

There shall be at least one telephone in a public area within easy reach of a person in a wheelchair (refer to 11.2).

14.6.5 Toilets

In a hotel or motel complex at least one accessible toilet shall be available in public areas of the complex for the use of hotel guests, casual patrons and staff.

At least one accessible toilet unit shall be provided for restaurant and bars.

14.6.6 Alerting devices

Alerting devices shall be provided on accessible routes and in accessible accommodation, refer to 4.12. Where the installation of an automatic fire alarm system is required, an alerting device shall be installed within every accessible accommodation unit. In all cases this alerting device shall be located within the unit in a position clearly visible from the bed or beds and have an audible and visible signal.

14.7 Accessible accommodation

14.7.1 General

Accessible accommodation requires consideration of the needs of the blind, the partially sighted, the deaf and hearing impaired, and of wheelchair users. The placing of controls, the use of bench tops, appliances etc. and the provision of adequate circulation space in all rooms are items to which the designer should give particular attention. Whatever kitchen facilities are to be provided, they shall be accessible as described below.

14.7.2 Car parks

There shall be at least one accessible car park for each accessible accommodation unit based on the following:

- (a) The ratio of accessible car parks to total car parks shall be the same ratio as accessible accommodation units to total units;
- (b) One accessible car park space for each accessible accommodation unit located as close as practicable to each unit and on an accessible route to that unit.

C14.6.3

These requirements enable guests with disabilities to move easily to and through the building to guest rooms, bars, dining room, swimming pools, spas, hair salons, shops, conference and function rooms.

C14.6.4

A seat located near to the telephone should be provided for ambulant people with disabilities.

C14.7.1

A doorbell with flashing internal lights will enable a person with a hearing disability to know that someone is requesting access.

Information on zones of reach for wheelchair users is to be found in Appendix D. (Figures D12 and D13).

All fittings should contrast with their background.

14.7.3 Doors

Doors and their catches shall comply with 4.11.

14.7.4 Kitchens and laundries

The facilities of kitchens and laundries shall be accessible having a clear floor space of 1500 mm x 1500 mm. Each item shall be within reachable range, refer Appendix D. Front loading washing machines and driers require 1500 mm clear front space.

14.7.4.1 Space dimensions

Minimum space dimensions are illustrated in figure 51.

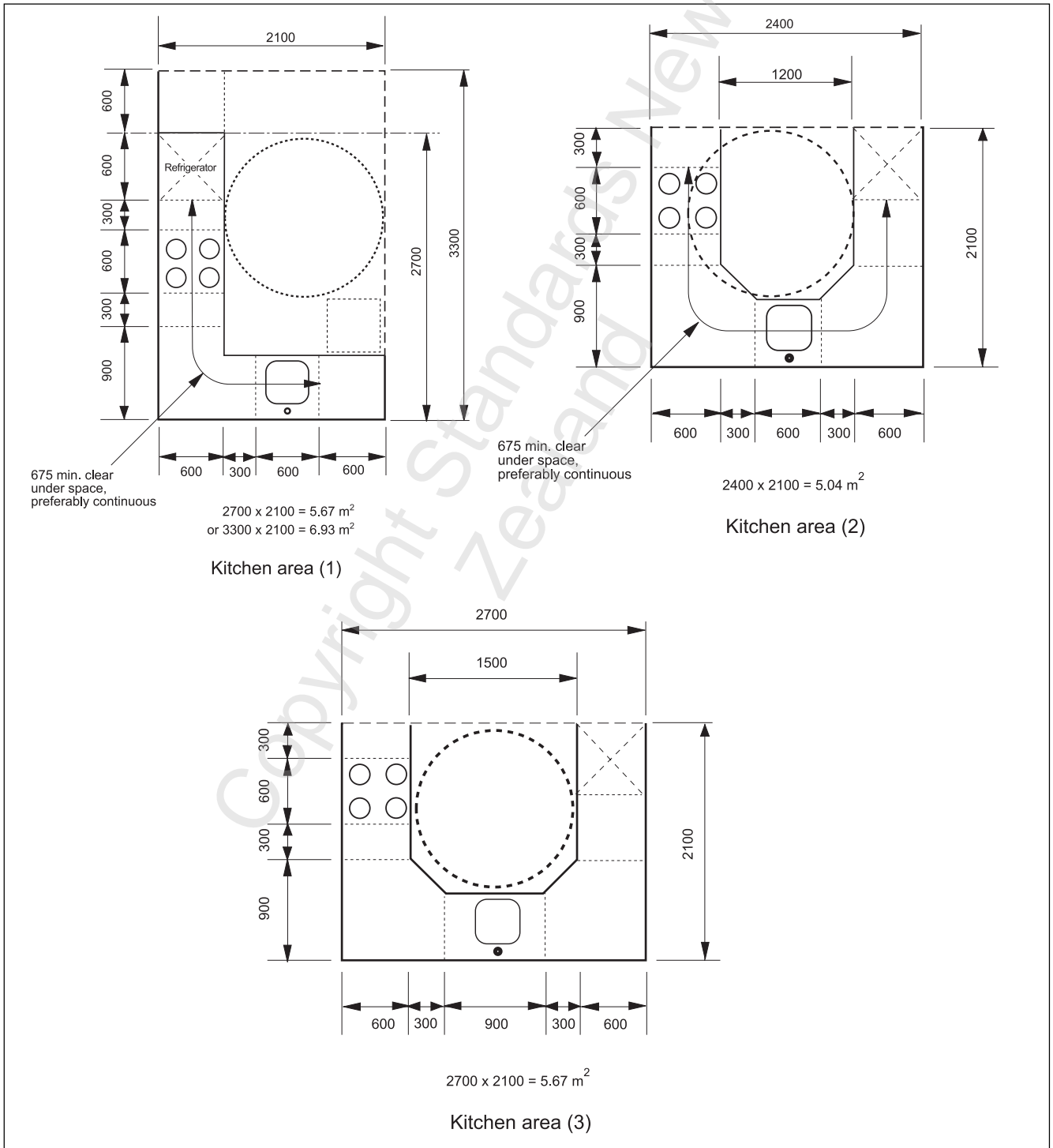

Figure 51 – Example of kitchen layout and dimensions

14.7.4.2 Work surfaces

Work surfaces shall:

- (a) Be at a consistent level and have an uninterrupted flow;
The user should be able to slide goods along the surfaces.
- (b) Be heat-resistant, where it is necessary to slide hot utensils along work surfaces;
- (c) Include a clear “set-down” space next to the oven cooktop, refrigerator and dishwasher;
- (d) Be smooth for easy cleaning;
- (e) Be of a non-glare finish;
- (f) Be a lighter colour than that of the vertical surfaces. The luminance factor of the vertical surface shall be not less than 0.3 (30 %) different from surrounding horizontal surface and the surface finished with a contrasting edge strip.
- (g) For people who are partially sighted, horizontal surfaces need to be easily distinguished from vertical surfaces. Fittings should contrast with their background.
- (h) Be set with the top surface at a height of 775 maximum and 675 minimum clear under space from the finished floor;
- (i) Have at least one work surface with a clear width opening beneath the surface of not less than 900 mm to allow for a front approach by a wheelchair.

14.7.4.3 Sinks

Sinks shall have a maximum bowl depth of 150 mm.

The clearance underneath shall comply with the requirements for washbasins (refer to 10.5.8.2). The underside of the sink bowl, exposed pipes, taps and fittings shall be insulated to avoid burns.

14.7.4.4 Taps

Taps shall be easily operated by a person with limited hand function; (refer to 10.5.8.2).

14.7.4.5 Ovens

Wall ovens, where provided, shall:

- (a) Have a door which on opening, does not obstruct access;
The drop-down type of oven door that does not slide away is not recommended as it limits reach for wheelchair users.
- (b) Be installed so that the bottom shelf is on approximately the same level as the adjacent work surface;
If a side-hinged oven door is used, the clear worktop should be on the opposite side to the hinges, see figure 52.
- (c) Have controls situated within the zone of common reach shown, see figure 52 and figures D14, D15 and D17;
- (d) Be easy to operate by the intended user and clearly marked;

C14.7.4.2

Some ambulant people with disabilities prefer to work while seated on a stool. Consideration should therefore be given to this when determining bench height.

Where pull-out work surfaces are provided, e.g. as a set-down beside a stove, they should be fitted with handles and heat-resistant surfaces. A stop should be incorporated to ensure that shelves cannot accidentally be pulled right out.

C14.7.4.3

A shallow sink is essential for users in wheelchairs and for short people.

C14.7.4.4

Wherever practicable, taps operating on the principle of a ball valve using synthetic rubber or ceramic or hydraseal type of washers should be used. These are generally easier to turn on and off, have a maintenance-free life and are easy to replace.

C14.7.4.8

Drawers or slide-out wire baskets are preferred, rather than large open cupboards.

Rotating shelves, which have a lip of not less than 5 mm, are preferred for corners.

Mobile storage units provide an efficient and practical method of storage in the kitchen. Mobile storage units can be kept in knee spaces below the preparation benches. The units can be moved to give more preparation space yet allow positioning close to meal preparation areas where utensils can be accessed easily.

Sliding doors should be fitted with stops so that the door stops a minimum distance of 50 mm from the door handle.

Handles should be easily grippable by people with impaired hand function.

- (e) Have a light and a timer.

For people with vision impairments, tactile indicators shall be provided on all controls.

14.7.4.6 Cooktops

Cooktops, where provided, shall:

- (a) Be flush or as close to flush as possible with the adjacent heat-resistant benchtops;
- (b) Have countertop controls;
- (c) Be positioned away from trafficable areas within the kitchen;
- (d) Have automatic ignition on gas burners;
- (e) For people with vision impairment have tactile markings on all controls.

14.7.4.7 Range hood

A range hood with an external exhaust is preferred to a recirculating type that requires regular filter changes.

14.7.4.8 Storage

Storage shall comply with the following:

- (a) Shelves, cupboards and drawers shall be designed and installed to allow the user to work in an organized manner, refer also to Appendix D, figures D13 to D18;
People who are blind or partially sighted need to be able to lay hands on the right implements and cooking ingredients safely and quickly.
- (b) Cupboard and drawer handles shall be:
 - (i) Able to accommodate the reach ranges in figures D13 and D18;
 - (ii) Shaped to provide easy grip for those with manipulative impairment;
 - (iii) Clearly identified by colour with a luminance contrast to the background of not less than 0.3 (30 %).
- (c) Clothes-hanging rods or hooks, set at a maximum of 1350 mm from the floor, shall be provided for wheelchair users (see figure D16).

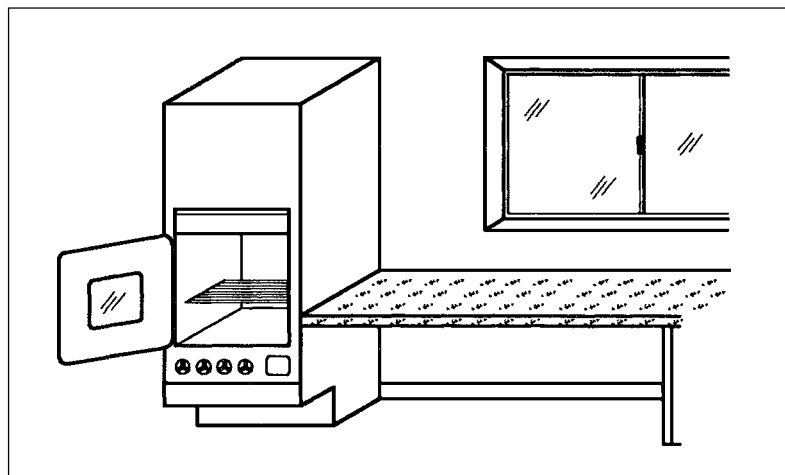

Figure 52 – Oven with worktop to allow for set-down

14.7.4.9 Benches

Corners of benches shall be rounded to reduce the risk of injury.

'Toe' recesses 250 – 300 mm high shall be provided along the front of all benches.

14.7.4.10 Refrigerator

A refrigerator shall be accessible (see figure 51).

The clear worktop space alongside a refrigerator shall be on the side opposite to the hinge of the door.

14.7.4.11 Dishwasher

Dishwashers, where provided, shall be installed close to the sink and crockery and cutlery storage areas.

14.7.4.12 Laundry tubs

Where laundry tubs are provided, at least one shall be installed at the height above floor level and with a clearance underneath that is in accordance with the requirements for washbasins, refer to 10.5.8 and NZBC G2/AS1.

14.7.4.13 Washing machine and dryer

Where washing machines are provided, at least one front-loading machine shall be available with controls clearly marked and easy to operate.

14.7.4.14 Shelves

Where shelving is provided, it shall be within a reachable range (see figures D16 and D17).

14.7.4.15 Ironing board

Where an ironing board is provided, it shall be securely fixed, dropdown or hinged, with sufficient manoeuvring space.

14.7.4.16 Clothes-line

Where a clothes-line is installed, it shall be on an accessible route.

It shall be usable by people who are either standing or seated and shall be installed so that its operating height is between 1000 mm and 1600 mm from the ground surface.

C14.7.4.12

These requirements are particularly for users in wheelchairs:

- (a) *Consideration may be given to installing a kitchen sink rather than a deep standard-sized laundry tub;*
- (b) *The tub should be accessible from the front. If it is not practical to provide knee access below laundry tubs, planning may allow for a parallel approach rather than a frontal approach.*

C14.7.4.13

Soft touch controls are preferred, located within a reachable range (see figures D14, D15 and D17).

Plumbing outlets for washing machines should be permanently fixed.

C14.7.4.14

Adjustable shelving is useful so that the space can be arranged to suit the individual.

C14.7.4.15

Portable ironing boards are often unsteady and difficult to erect.

14.7.4.17 Power outlets

Switches for electric light and power shall comply with the following requirements:

- (a) All light switches shall be horizontally aligned with door handles, except that at least one room light shall have a bedside switch;
- (b) The toggle, rocker, push pad, or push button control of light switches shall project clear of the switch plate;
- (c) Socket outlets shall be fixed between 500 mm and 1200 mm above the finished floor level and at least 500 mm from corners;
- (d) Switches and socket outlets shall contrast in colour to their surroundings.

14.7.4.18 Lighting

Lighting shall comply with 4.10.3.

14.7.4.19 Dining and lounge space dimensions

Minimum space dimensions for dining and lounge rooms are shown in figure 53.

14.7.5 Bedrooms

14.7.5.1 Minimum space dimensions

Minimum space dimensions for bedrooms are shown in figure 54.

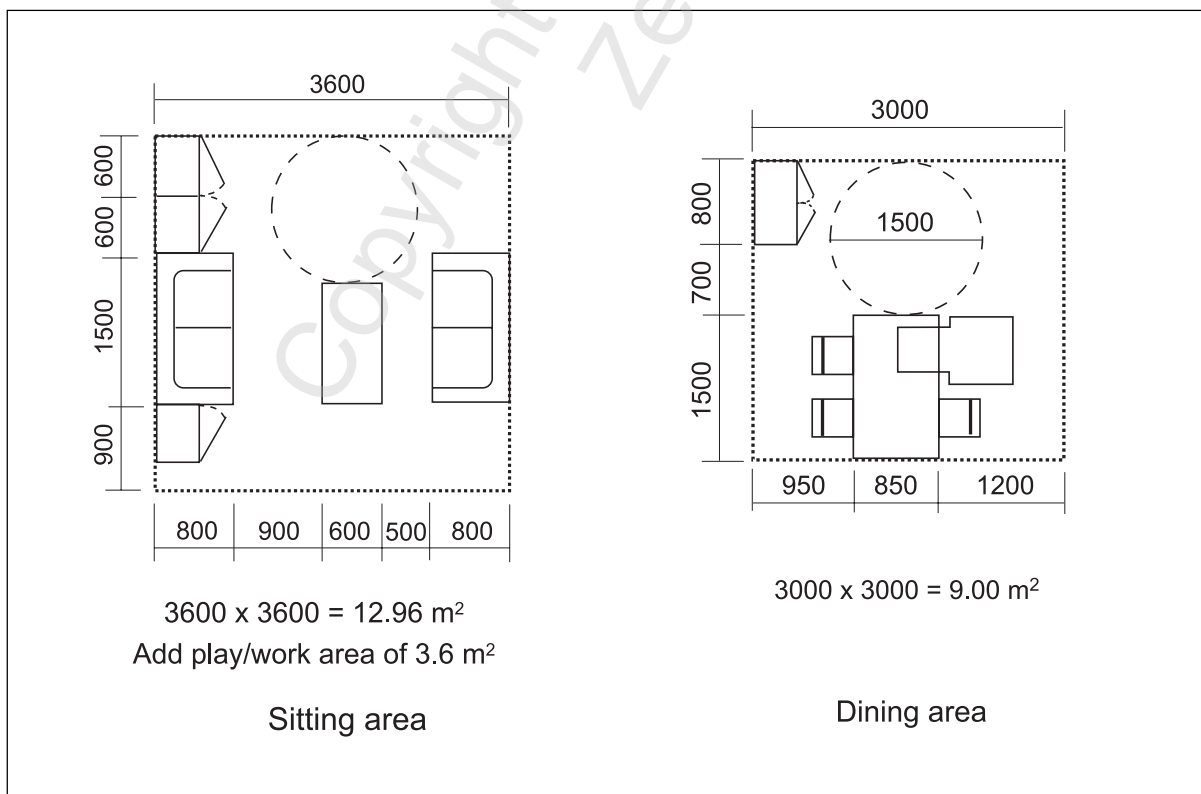

Figure 53 – Example of dining and lounge layout and dimensions

14.7.5.2 Access to facilities

People with disabilities shall be able to move freely around the bed and shall be able to reach the:

- (a) Tea/coffee making facilities;
- (b) Door handles;
- (c) Light switches;
- (d) Curtain pull cords;
- (e) Wardrobe rail;
- (f) Extra pillows and blankets;
- (g) Telephone;
- (h) Television and radio controls.

Telephones in accessible units shall be adjacent to a bed and be located on that side of the bed to which there is wheelchair access.

14.7.6 Wall and floor finishes

Floor surfaces shall be easy to maintain and slip-resistant when wet or dry.

14.7.7 Bathroom/toilet/shower

The toilet/shower aspects of a bathroom/toilet/shower unit in accessible accommodation shall meet the requirements for accessible toilets and showers of section 10.

C14.7.7

The general principle of being able to reach items such as a towel rail, hairdryer, shaving point and a bathroom heater shall apply. Mirrors should be placed at usable heights (see figure 31).

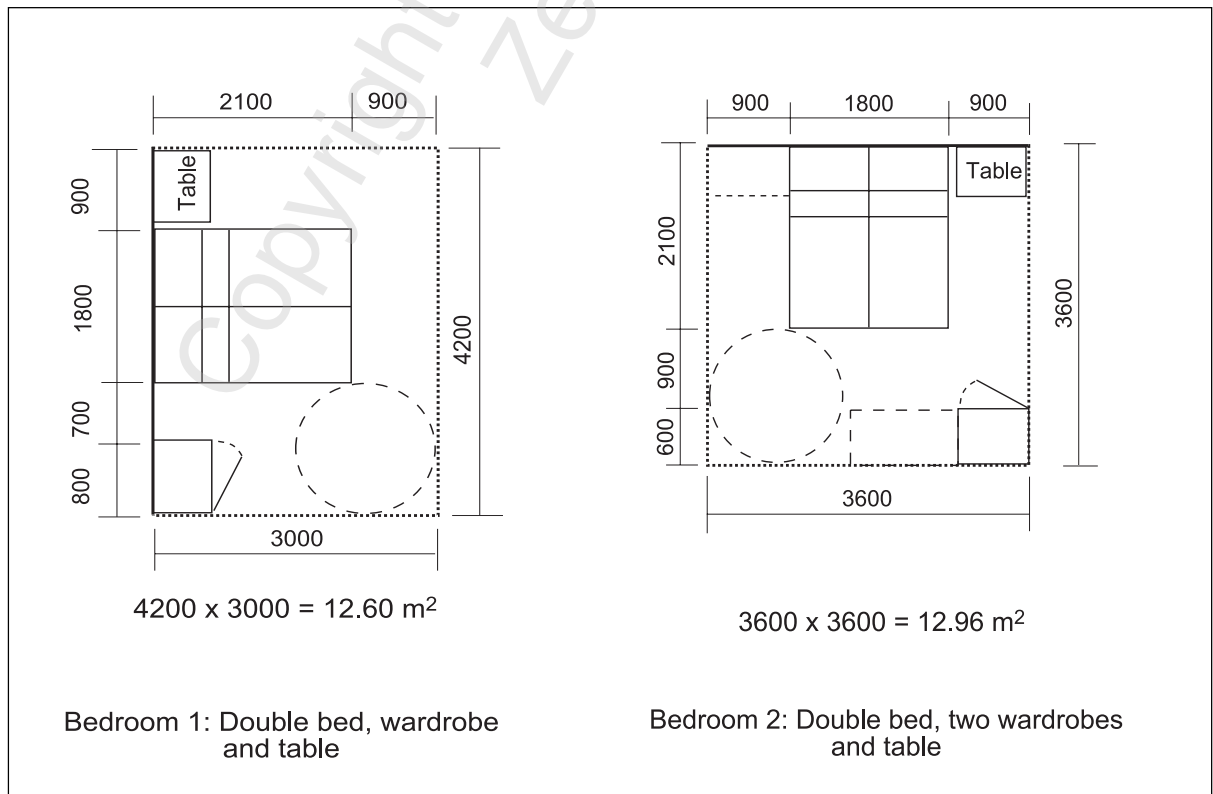

Figure 54 – Example of bedroom layout and dimensions

14.7.8 Motor camps, camping grounds, holiday parks, resorts, backpackers, lodges and hostels, etc.**14.7.8.1 Car parks**

One car parking space shall be provided for each accessible unit, immediately adjacent wherever possible.

14.7.8.2 Accessible units

Accessible units shall be connected to the communal facilities by an accessible route.

14.7.8.3 Toilet/showers

Where an ablution block contains communal toilet and bathroom facilities all-gender combined toilet, hand basin, and shower shall be provided in accordance with table 3.

Table 3 – Number of toilets

Users	All-gender facility
1 – 100	1
101 – 300	2
300 or more	3

14.7.8.4 Communal facilities

All communal facilities including reception, office, shop, dining room, kitchen, laundry, ablution block and recreation rooms shall be usable areas connected to an accessible route.

APPENDIX

A	Statutory obligations relating to access and building	89
B	Performance requirements of the New Zealand Building Code relating to access and facilities for people with disabilities	94
C	Design for access and mobility – Alterations to buildings	102
D	People with disabilities – Mobility and mobility aid information	107
E	International symbols	117
F	Handrails and grab rails	119
G	Scissor stairs	121
H	Hearing augmentation – Listening systems	123

NOTES

Copyright Standards New
Zealand

APPENDIX A

STATUTORY OBLIGATIONS RELATING TO ACCESS AND BUILDING

(Informative)

A1 Scope

This Appendix covers legislation that has a direct effect on the provision of access and facilities for people with disabilities.

A2 Purpose

The Appendix is intended to draw to the attention of designers, building owners and territorial councils the obligations laid down by New Zealand law when designing a building or operating a building.

A3 Building Act 1991

The Building Act in its purpose section 6(2)(e) refers to the need to:

“Provide, both to and within buildings to which section 47A of this Act applies, means of access and facilities that meet the requirements of that section to ensure that reasonable and adequate provision is made for people with disabilities to enter and carry out normal activities and processes in those buildings.”

A3.1 Obligations of building owner and designer

The full text of the access requirement in section 47A of the Building Act 1991 is:

“47A. ACCESS AND FACILITIES FOR PERSONS WITH DISABILITIES TO AND WITHIN BUILDINGS –

(1) In any case where provision is being made for the construction or alteration of any building to which the public are to be admitted, whether on payment or otherwise, reasonable and adequate provision by way of access, parking provisions, and sanitary conveniences, shall be made for persons with disabilities who may be expected to visit or work in that building and carry out normal activities and processes in that building.

“(2) Notwithstanding the provisions of subsection (1) of this section, in respect of the alteration of any existing building or premises, the Building Industry Authority may at any time by determination under Part III of this Act provide for a waiver or modification from all or any of the requirements of this section if, having regard to all the circumstances, the Building Industry Authority determines that it is reasonable to grant the waiver or modification.

“(3) Any provision that is made to meet the requirements of disabled persons in accordance with New Zealand Standard Specification No 4121 (being the code of practice for design for access and use of buildings by persons with disabilities) and any amendments thereof (whether made before or after the commencement of this subsection), or in accordance with any standard specification that is in substitution therefor, shall, in respect of matters subject to this Act, be deemed to be one of the documents establishing compliance with the building code for the purposes of section 49 of this Act.

“(4) The provisions of this section shall apply to, but shall not be limited to, buildings, and parts of buildings, (including driveways, accessways, and passages within and between complexes and developments, and associated

landscaping, if any) that are intended to be used for or associated with one or more of the following purposes:

- (a) Land, sea, and air passenger transport terminals and facilities and interchanges, whether wholly on land or otherwise:
- (b) Public toilets wherever situated:
- (c) Banks:
- (d) Childcare centres and kindergartens:
- (e) Day-care centres and facilities:
- (f) Commercial buildings and premises for business and professional purposes, including computer centres:
- (g) Central, regional, and local government offices and facilities:
- (h) Courthouses:
- (i) Police stations:
- (j) Hotels, motels, hostels, halls of residence, holiday cabins, groups of pensioner flats, boarding-houses, guest houses, and other premises providing accommodation for the public:
- (k) Hospitals, whether public or private, nursing homes, and old people's homes:
- (l) Medical and dental surgeries, and medical and paramedical and other primary health care centres:
- (m) Educational institutions, including public and private primary, intermediate, and secondary schools, universities, polytechnics, and other tertiary institutions:
- (n) Libraries, museums, art galleries, and other cultural institutions:
- (o) Churches, chapels, and other places of public worship:
- (p) Places of assembly, including auditoriums, theatres, cinemas, halls, sports stadiums, conference facilities, clubrooms, recreation centres, and swimming baths:
- (q) Shops, shopping centres, and shopping malls:
- (r) Restaurants, bars, cafeterias, and catering facilities:
- (s) Showrooms and auction rooms:
- (t) Public laundries:
- (u) Petrol and service stations:
- (v) Funeral parlours:
- (w) Television and radio stations:
- (x) Car parks, parking buildings, and parking facilities:
- (y) Factories and industrial buildings where more than 10 persons are employed:
- (z) Other buildings, premises, or facilities to which the public are to be admitted, whether on payment or otherwise.

“(5) Where any provision required by this section is made at a building in compliance therewith, a notice or sign that indicates in accordance with the international access symbol that provision is made for the needs of persons with disabilities shall be displayed outside the building or so as to be visible from outside it.

“(6) For the purposes of this section, the term “person with a disability” means any person who suffers from physical or mental disability to such a degree that he or she is seriously limited in the extent to which he or she can engage in the activities, pursuits, and processes of everyday life.”

A3.2 Obligations of the Crown

Section 5 of the Building Act 1991 binds the Crown.

A4 Obligations of the Council

A4.1 Footpaths and channels

The Council shall provide safe and easy passage for people with disabilities from kerb to kerb of any road.

Section 331 of the Local Government Act 1974 provides:

“(1) []The council may, in such manner as it thinks fit, form [[or upgrade]] footpaths on one side or both sides of any road, and may construct those footpaths of such dimensions and of such materials and in such manner as it thinks fit, and may impose a charge not exceeding half the cost of those works upon the owners of lands and buildings fronting the road. The amount so imposed shall be payable to the council and until paid shall be in every case a charge on the land.

“(2) In forming or reforming any road or part thereof (not being a road in a rural area), the council shall ensure that reasonable and adequate provision is made for the kerb and channel of any footpath or part thereof to be formed or reformed so as to permit safe and easy passage from kerb to kerb of any mechanical conveyance normally and lawfully used by a disabled person:

“Provided that the [Director of Land Transport Safety] may at any time exempt in whole or in part the forming or reforming of any road or part thereof from any requirements of this subsection, if, having regard to all circumstances, he considers that it is reasonable to grant the exemption.”

A4.2 Alterations and changes of use

Section 38 of the Building Act states that:

“No building consent shall be granted for the alteration of an existing building unless the territorial authority is satisfied that after the alteration the building will –

- (a) Comply with the provisions of the building code for means of escape from fire, and for access and facilities for use by people with disabilities (where this is a requirement in terms of section 47A of this Act), as nearly as is reasonably practicable, to the same extent as if it were a new building; and
- (b) Continue to comply with the other provisions of the building code to at least the same extent as before the alteration.”

When processing a Building Consent, Section 34(7) of the Building Act also prohibits territorial authorities from granting a waiver or modification of the Building Code, or any document intended for use in establishing compliance with the Building Code, relating to access and facilities for people with disabilities. (Also refer section 47A(2) in A3.1 of this Appendix).

Similar provisions apply with respect to the changes of use of buildings under section 46 of the Building Act.

“Change of use of buildings, etc.—

“(1) It is the duty of an owner of a building to advise the territorial authority in writing if it is proposed—

- (a) To change the use of a building and the change of use will require alterations to the building in order to bring that building into compliance with the building code; or
- (b) To extend the life of a building that has a specified intended life in terms of section 39 of this Act.

“(2) The use of the building shall not be changed unless the territorial authority is satisfied on reasonable grounds that in its new use the building will –

- (a) Comply with the provisions of the building code for means of escape from fire, protection of other property, sanitary facilities, and structural and fire-rating behaviour, and for access and facilities for use by people with disabilities (where this is a requirement in terms of section 47A of the Building Act) as nearly as is reasonably practicable to the same extent as if it were a new building; and
- (b) Continue to comply with the other provisions of the building code to at least the same extent as before the change of use.

“(4) Where a territorial authority is required to consider an application for the issue of a certificate pursuant to section 224 (f) of the Resource Management Act 1991 for the purpose of giving effect to a subdivision which affects a building or any part thereof, the territorial authority shall only issue that certificate if it is satisfied on reasonable grounds that the building will –

- (a) Comply with the provisions of the building code for means of escape from fire, protection of other property, and access and facilities for use by people with disabilities (where this is a requirement in terms of section 47A of the Building Act) as nearly as is reasonably practicable to the same extent as if it were a new building; and
- (b) Continue to comply with the other provisions of the building code to at least the same extent as before the application for a subdivision affecting that building or part thereof was made.”

A5 Human Rights Act 1993

Section 43(3) states that:

"Nothing in subsection (2) of this section limits the provisions of section 47A of the Building Act 1991."

A6 Resource Management Act 1991

The Second Schedule to the Resource Management Act 1991 covers matters that may be provided for in Policy Statements and Plans. It provides in both Part I (Matters related to Regions) and Part II (Matters related to Districts) for the inclusion of any matter relating to the management of any actual or the potential effects of any use, development or protection described in Parts I and II of the Schedule on the community or any group within the community (including minorities, children and disabled people).

A7 Fire Safety (Evacuation of Buildings) Regulation 1992

Regulation 21 of the Fire Safety (Evacuation of Buildings) Regulation 1992 provides that:

"No problems of fire safety and evacuation from a building shall be a cause to limit or prevent any person with disabilities from entering or carrying out normal activities and processes within the building, or any part of it, which the person would otherwise be permitted to enter or use."

APPENDIX B PERFORMANCE REQUIREMENTS OF THE NEW ZEALAND BUILDING CODE RELATING TO ACCESS AND FACILITIES FOR PEOPLE WITH DISABILITIES

(Informative)

B1 Scope

This Appendix covers the performance requirements of the New Zealand Building Code relating to access and facilities for people with disabilities.

B2 Building Regulations 1992

The Building Code in the First Schedule to the Building Regulations 1992 prescribes the objectives together with the functional requirements for buildings and the performance criteria with which buildings must comply in their intended use.

The objectives in respect of access and facilities for people with disabilities is to ensure that they are able to carry out normal activities, functions and processes within buildings as required by section 47A (previously Section 25 of the DPCW Act 1975) of The Building Act with respect to people with disabilities includes the objectives, functional requirements and performance criteria described below.

The 'performance requirements' of the Code clauses related to specific building matters must be complied with, whereas the 'functional requirements' are present essentially to define the purpose and scope of the performance requirements.

B3 Performance objectives

The parts of the Building Code clauses quoted below are those with specific provisions for people with disabilities.

NOTE – All words in the following section that are in *italics* are defined in the New Zealand Building Code Handbook.

Provisions	Limits on application
<p>Clause D1 – ACCESS ROUTES</p> <p>OBJECTIVE</p> <p>D1.1 The objective of this provision is to:</p> <p>(a) Safeguard people from injury during movement into, within and out of <i>buildings</i>,</p> <p>(b) Safeguard people from injury resulting from the movement of vehicles into, within and out of <i>buildings</i>, and</p> <p>(c) Ensure that <i>people with disabilities</i> are able to enter and carry out normal activities and functions within <i>buildings</i>.</p> <p>FUNCTIONAL REQUIREMENT</p> <p>D1.2.1 <i>Buildings</i> shall be provided with reasonable and adequate access to enable safe and easy movement of people.</p> <p>D1.2.2 Where a <i>building</i> is provided with loading or parking spaces, they shall be constructed to permit safe and easy unloading and movement of vehicles, and to avoid conflict between vehicles and pedestrians.</p>	<p>Objective D1.1(c) shall apply only to those <i>buildings</i> to which section 47A of the Building Act 1991 applies.</p> <p>Requirement D1.2.1 shall not apply to <i>Ancillary buildings</i> or <i>Outbuildings</i>.</p>

Provisions	Limits on application
PERFORMANCE	
D1.3.2 At least one <i>access route</i> shall have features to enable <i>people with disabilities</i> to:	Performance D1.3.2 shall not apply to <i>Housing, Outbuildings, Ancillary buildings</i> , and to <i>Industrial buildings</i> where no more than 10 people are employed.
(a) Approach the <i>building</i> from the street boundary or, where required to be provided, the <i>building car park</i> ,	
(b) Have access to the internal space served by the principal access, and	
(c) Have access to and within those spaces where they may be expected to work or visit, or which contain facilities for personal hygiene as required by Clause G1 “Personal Hygiene”.	
D1.3.3 Access routes shall:	
(a) Have <i>adequate</i> activity space,	
(b) Be free from dangerous obstructions and from any projections likely to cause an obstruction,	
(c) Have a safe cross fall, and safe slope in the direction of travel,	
(d) Have <i>adequate</i> slip-resistant walking surfaces under all conditions of normal use,	
(e) Include stairs to allow access to upper floors irrespective of whether an escalator or lift has been provided,	
(f) Have stair treads, and ladder treads or rungs which:	
(i) provide <i>adequate</i> footings, and	
(ii) have uniform rise within each flight and for consecutive flights,	
(g) Have stair treads with a leading edge that can be easily seen,	
(h) Have stair treads which prevent children falling through or becoming held fast between treads, where open risers are used,	Performance D1.3.3(h) shall not apply within <i>Industrial buildings, Outbuildings</i> and <i>Ancillary buildings</i> .
(i) Not contain isolated steps,	Performance D1.3.3(i) shall not apply with <i>Detached Dwellings</i> or within <i>household units</i> of <i>Multi-unit Dwellings</i> , or to <i>Outbuildings</i> and <i>Ancillary buildings</i> .
(j) Have smooth, reachable and graspable <i>handrails</i> to provide support and to assist with movement along a stair or ladder,	Performance D1.3.3(j) shall not apply to isolated steps.
(k) Have <i>handrails</i> of <i>adequate</i> strength and rigidity as required by Clause B1 “Structure”,	
(l) Have landings of appropriate dimensions and at appropriate intervals along a stair or ramp to prevent undue fatigue,	
(m) Have landings of appropriate dimensions where a door opens from or onto a stair, ramp or ladder so that the door does not create a hazard, and	
(n) Have any automatically controlled doors <i>constructed</i> to avoid the risk of people becoming caught or being struck by moving parts.	

Provisions	Limits on application
<p>D1.3.4 An <i>accessible route</i>, in addition to the requirement of Clause D1.3.3, shall:</p> <ul style="list-style-type: none"> (a) Be easy to find, as required by Clause F8 “Signs”, (b) Have <i>adequate</i> activity space to enable a person in a wheelchair to negotiate the route while permitting an ambulant person to pass, (c) Include a lift complying with Clause D2 “Mechanical Installations for Access” to upper floors where: <ul style="list-style-type: none"> (i) <i>buildings</i> are four or more storeys high, (ii) <i>buildings</i> are three storeys high and have a total design occupancy of 50 or more persons on the two upper floors, (iii) <i>buildings</i> are two storeys high and have a total design occupancy of 40 or more persons on the upper floor, or (iv) an upper floor, irrespective of design occupancy, is to be used for the purposes of public reception areas of banks, central, regional and local government offices and facilities, hospitals, medical and dental surgeries, and medical, paramedical and other primary health care centres, (d) Contain no thresholds or upstands forming a barrier to an unaided wheelchair user, (e) Have means to prevent the wheel of a wheelchair dropping over the side of the <i>accessible route</i>, (f) Have doors and related hardware which are easily used, (g) Not include spiral stairs, or stairs having open risers, (h) Have stair treads with a leading edge which is rounded, and (i) Have <i>handrails</i> on both sides of the <i>accessible route</i> when the slope of the route exceeds 1 in 20. The <i>handrails</i> shall be continuous along both sides of the stair, ramp and landing except where the <i>handrail</i> is interrupted by a doorway. 	
<p>D1.3.5 Vehicle spaces and circulation routes shall have:</p> <ul style="list-style-type: none"> (a) Dimensions appropriate to the <i>intended use</i>, (b) Appropriate crossfall, and slope in the direction of travel, (c) <i>Adequate</i> queuing and circulation space, and (d) <i>Adequate</i> sight distances. 	
<p>D1.3.6 Vehicle spaces for use by <i>people with disabilities</i>, shall, in addition to the requirements of Clause D1.3.5, be:</p> <ul style="list-style-type: none"> (a) Provided in sufficient numbers, (b) Located to avoid conflict between vehicles and people using or moving to or from the space, and (c) Easy to find as required by Clause F8 “Signs”. 	

Provisions	Limits on application
<p>Clause D2 – MECHANICAL INSTALLATIONS FOR ACCESS</p> <p>OBJECTIVE</p> <p>D2.1 The objective of this provision is to:</p> <ul style="list-style-type: none"> (a) Safeguard people from injury and loss of amenity while using mechanical installations for movement into, within and out of <i>buildings</i>, (b) Safeguard maintenance personnel from injury while servicing mechanical installations for access, and (c) Ensure that <i>people with disabilities</i> are able to carry out normal activities and processes within <i>buildings</i>. <p>FUNCTIONAL REQUIREMENT</p> <p>D2.2 Mechanical installations for access into, within and out of <i>buildings</i> shall provide for the safe and easy movement of people, and for the safety of maintenance personnel.</p> <p>PERFORMANCE</p> <p>D2.3.5 Mechanical installations on <i>accessible routes</i> shall:</p> <ul style="list-style-type: none"> (a) Where the passenger conveyor is manually controlled, provide: <ul style="list-style-type: none"> (i) controls which are easily identifiable and easy to use, (ii) <i>adequate</i> notification that the passenger conveyor has registered a summoning call, and (iii) <i>adequate</i> notification that the passenger conveyor has arrived, and of its future direction of travel, (b) Where the passenger conveyor is fully enclosed and serves more than two levels, provide an <i>adequate</i> means of informing occupants of their location, (c) Where appropriate, have doors which: <ul style="list-style-type: none"> (i) are power operated, (ii) are readily distinguishable from their surroundings, and (iii) where automatic, remain open sufficiently long to enable <i>people with disabilities</i> to pass through, and (d) Have <i>handrails</i> within the passenger conveyor. <p>Clause F8 – SIGNS</p> <p>OBJECTIVE</p> <p>F8.1 The objective of this provision is to:</p> <ul style="list-style-type: none"> (a) Safeguard people from injury or illness resulting from inadequate identification of <i>escape routes</i>, or of hazards within or about the <i>building</i>, (b) Safeguard people from loss of <i>amenity</i> due to inadequate direction, and 	<p>Objective D2.1(c) shall apply only to those buildings to which section 47A of the Building Act applies.</p>

Provisions	Limits on application
<p>(c) Ensure that <i>people with disabilities</i> are able to carry out normal activities and processes within <i>buildings</i>.</p>	<p>Objective F8.1(c) shall apply only to those <i>buildings</i> to which section 47A of the Building Act 1991 applies.</p>
FUNCTIONAL REQUIREMENT	
<p>F8.2 Signs shall be provided in and about <i>buildings</i> to identify:</p>	<p>Requirement F8.2 shall not apply to <i>Detached Dwellings</i>, or within <i>household units</i> of <i>Multi-unit Dwellings</i>.</p>
<p>(a) Escape routes, (b) Emergency related safety features, (c) Potential hazards, and (d) Accessible routes and facilities for <i>people with disabilities</i>.</p>	
PERFORMANCE	
<p>F8.3.1 Signs shall be clearly visible and readily understandable under all conditions of foreseeable use.</p>	
<p>F8.3.2 Signs indicating potential hazards shall be provided in sufficient locations to notify people before they encounter the hazard.</p>	
<p>F8.3.3 Signs to facilitate escape shall:</p>	
<p>(a) Be provided in sufficient locations to identify <i>escape routes</i> and guide people to a <i>safe place</i>, and (b) Remain visible in the event of a power failure of the main lighting supply, for the same duration as required by Clause F6 'Lighting for Emergency'.</p>	
<p>F8.3.4 Signs shall be provided in sufficient locations to identify <i>accessible routes</i> and facilities provided for <i>people with disabilities</i>.</p>	
Clause G1 – PERSONAL HYGIENE	
OBJECTIVE	
<p>G1.1 The objective of this provision is to:</p>	
<p>(a) Safeguard people from illness caused by infection or contamination, (b) Safeguard people from loss of <i>amenity</i> arising from the absence of appropriate personal hygiene facilities, and (c) Ensure <i>people with disabilities</i> are able to carry out normal activities and processes within <i>buildings</i>.</p>	<p>Objective G1.1(c) shall apply only to those <i>buildings</i> to which section 47A of the Building Act 1991 applies.</p>
PERFORMANCE	
<p>G1.2 <i>Buildings</i> shall be provided with appropriate spaces and facilities for personal hygiene.</p>	
<p>G1.3.4 Personal hygiene facilities provided for <i>people with disabilities</i> shall be <i>accessible</i>.</p>	<p>Performance G1.3.4 shall not apply to <i>Housing</i>, <i>Outbuildings</i>, <i>Ancillary buildings</i>, and to <i>Industrial buildings</i> where no more than 10 people are employed.</p>

Provisions	Limits on application
<p>Clause G2 – LAUNDERING</p> <p>OBJECTIVE</p> <p>G2.1 The objective of this provision is to ensure:</p> <p>(a) <i>Adequate amenities</i> for people to do laundering, and</p> <p>(b) That <i>people with disabilities</i> are able to carry out normal activities and processes within <i>buildings</i>.</p> <p>FUNCTIONAL REQUIREMENT</p> <p>G2.2 <i>Buildings</i> shall be provided with <i>adequate</i> space and facilities for laundering.</p> <p>G2.3.4 <i>Accessible</i> facilities shall be provided for <i>people with disabilities</i>.</p>	<p>Objective G2.1(b) shall apply only to those <i>buildings</i> to which section 47A of the Building Act 1991 applies.</p> <p>Requirement G2.2 shall apply only to <i>Housing</i>, old people’s homes, early childhood centres, camping grounds and work camps.</p> <p>Performance G2.3.4 shall apply only to camping grounds.</p>
<p>Clause G3 – FOOD PREPARATION AND PREVENTION OF CONTAMINATION</p> <p>OBJECTIVE</p> <p>G3.1 The objective of this provision is to:</p> <p>(a) Safeguard people from illness due to contamination,</p> <p>(b) Enable hygienic food preparation without loss of <i>amenity</i>, and</p> <p>(c) Ensure that <i>people with disabilities</i> are able to carry out normal activities and processes within <i>buildings</i>.</p> <p>FUNCTIONAL REQUIREMENT</p> <p>G3.2.1 <i>Buildings</i> shall be provided with space and facilities for the hygienic storage, preparation and cooking of food, that are <i>adequate</i> for the <i>intended use</i> of the <i>building</i>.</p> <p>PERFORMANCE</p> <p>G3.3.5 Where facilities are provided for <i>people with disabilities</i> they shall be <i>accessible</i>.</p>	<p>Objective G3.1(c) shall apply only to those <i>buildings</i> to which section 47A of the Building Act 1991 applies.</p> <p>Requirement G3.2.1 shall apply to <i>Housing</i>, work camps, old people’s homes and early childhood centres, and where appropriate shall also apply to <i>Commercial</i> and <i>Industrial buildings</i> whose intended uses include the manufacture, preparation, packaging or storage of food.</p> <p>Performance G3.3.5 shall apply only to camping grounds and <i>accessible</i> accommodation units in <i>Communal Residential buildings</i>.</p>

Provisions	Limits on application
Clause G5 – INTERIOR ENVIRONMENT	
OBJECTIVE	
G5.1 The objective of this provision is to:	
(a) Safeguard people from illness caused by low air temperature	
(b) Safeguard people from injury or loss of <i>amenity</i> caused by inadequate activity space	
(c) Safeguard people from injury caused by unsafe installations and	
(d) Ensure that <i>people with disabilities</i> are able to carry out normal activities and processes within <i>buildings</i> .	Objective G5.1(d) shall apply only to those <i>buildings</i> to which section 47A of the Building Act 1991 applies.
FUNCTIONAL REQUIREMENT	
G5.2.1 <i>Buildings</i> shall be <i>constructed</i> to provide:	
(a) An <i>adequate</i> , controlled interior temperature	Requirement G5.2.1(a) shall apply only to <i>habitable</i> spaces, bathrooms and recreation rooms in old people's homes and early childhood centres.
(b) <i>Adequate</i> activity space for the <i>intended use</i> , and	Requirement G5.2.1(b) shall apply only to old people's homes.
(c) <i>Accessible</i> spaces and facilities.	Requirement G5.2.1(c) shall apply only to <i>Communal Residential</i> , <i>Communal Non-residential</i> , and <i>Commercial buildings</i> .
G5.2.2 Heating appliances in <i>buildings</i> shall be installed in a way that reduces the likelihood of injury.	
PERFORMANCE	
G5.3.2 Heating appliances, and any attached cables, pipes or other fittings shall be securely fixed in place.	Performance G5.3.2 shall apply only to old people's homes and early childhood centres.
G5.3.3 <i>Habitable</i> spaces shall have sufficient space for activity, furniture, and sanitary and mobility aids.	Performance G5.3.3 shall apply only to old people's homes.
G5.3.4 Where reception counters or desks are provided for public use, at least one counter or desk shall be <i>accessible</i> .	Performance G5.3.4 applies only to <i>Communal Residential</i> , <i>Communal Non-residential</i> , and <i>Commercial buildings</i> .
G5.3.5 <i>Buildings</i> shall be provided with listening systems which enable enhanced hearing by people with hearing aids.	Performance G5.3.5 applies only to:
	(a) <i>Communal Non-residential</i> assembly spaces occupied by more than 250 people, and
	(b) Any theatre, cinema, or public hall, and
	(b) Assembly spaces in old people's homes occupied by more than 20 people.
G5.3.6 Enhanced listening systems shall be identified by signs complying with Clause F8 "Signs".	

Provisions	Limits on application
<p>Clause G9 – ELECTRICITY</p> <p>OBJECTIVE</p> <p>G9.1 The objective of this provision is to ensure that:</p> <ul style="list-style-type: none"> (a) In <i>buildings</i> supplied with electricity, the <i>electrical installation</i> has safeguards against outbreak of <i>fire</i> and personal injury, and (b) <i>People with disabilities</i> are able to carry out normal activities and processes within <i>buildings</i>. <p>FUNCTIONAL REQUIREMENT</p> <p>G9.2 Where provided in a <i>building</i>, <i>electrical installations</i> shall be safe for their <i>intended use</i>.</p> <p>PERFORMANCE</p> <p>G9.3.4 In <i>buildings</i> intended for use by <i>people with disabilities</i>, light switches and plug socket outlets shall be <i>accessible</i> and usable.</p>	<p>Objective G9.1(b) shall apply only to those <i>buildings</i> to which section 47A of the Building Act 1991 applies.</p> <p>Performance G9.3.4 shall not apply to <i>Housing, Outbuildings, Ancillary buildings</i>, and to <i>Industrial buildings</i> where no more than 10 people are employed.</p>
<p>Clause G12 – WATER SUPPLIES</p> <p>OBJECTIVE</p> <p>G12.1 The objective of this provision is to:</p> <ul style="list-style-type: none"> (a) Safeguard people from illness caused by infection from contaminated water or food, (b) Safeguard people from injury due to the explosion of a pressure vessel or from contact with excessively hot water, (c) Safeguard people from loss of <i>amenity</i> arising from lack of hot water for personal hygiene, or from a water supply which is offensive in appearance or odour, and (d) Ensure that <i>people with disabilities</i> are able to carry out normal activities and functions within <i>buildings</i>. <p>FUNCTIONAL REQUIREMENT</p> <p>G12.2 <i>Buildings</i>, provided with drinking water outlets, <i>sanitary fixtures</i> or <i>sanitary appliances</i>, shall have a safe and <i>adequate</i> piped water supply.</p> <p>PERFORMANCE</p> <p>G12.3.8 Water supply taps shall be accessible and usable for <i>people with disabilities</i>.</p>	<p>Objective G12.1(d) shall apply only to those <i>buildings</i> to which section 47A of the Building Act 1991 applies.</p> <p>Performance G12.3.8 shall not apply to <i>Housing, Outbuildings, Ancillary buildings</i>, and to <i>Industrial buildings</i> where no more than 10 people are employed.</p>

APPENDIX C DESIGN FOR ACCESS AND MOBILITY – ALTERATIONS TO BUILDINGS

(Normative)

CC3 Discussion on alterations

Even when it is not possible to make an altered building accessible to the extent necessary to enable its full use by an unaided wheelchair user because, for example, existing structural conditions would require removing or altering a load bearing member which is an essential part of the structure frame, or because other existing physical or site constraints prevent complete compliance, the alteration must still provide accessibility to the full extent possible. Any elements or features of the altered building that can be made accessible shall comply with the access requirements. It is possible in most cases for workable access to be provided for ambulant people with disabilities.

If it has been decided under, S38 and S46 of the Building Act that it is not reasonably practicable to install a lift then the ground floor of the building has to have access and facilities, and the upper floor or floors still have to be made accessible for ambulant people with disabilities. One of the main features, which assist ambulant people with disabilities, is the installation of handrails on both sides of stairs and steps. Sometimes a centre handrail on external steps is a workable alternative when it is not possible to fix a handrail on each side of the steps.

C1 Scope

Sections 38 and 46 of the Building Act refer to alterations and changes of use of buildings. This Appendix relates to section 3 of this Standard: Design rules for access and mobility, which establishes the design parameters for the construction of new buildings.

C2 General

When an existing building is altered, the alteration shall not have the effect of decreasing accessibility or usability of the building to less than it was before the alteration.

When an existing building is to be altered, all accessible aspects, as detailed in sections 2 to 14 of this Standard, shall be reviewed and the provisions complied with as nearly as is reasonably practicable.

C3 Application

The design solutions given in this Appendix are suggested as ways of meeting the requirement to provide access and facilities “as nearly as is reasonably practicable, to the same extent as if it was a new building”. They are to be used only when there is no other way of bringing the building into compliance with the Building Code. They shall not be used in new buildings.

Section 47 of the Building Act

In the exercise of its powers under sections 46 and 64 to 71 of, and the third Schedule to, this Act the territorial authority shall have due regard to the following matters:

- (a) The size of the building;
- (b) The complexity of the building;
- (c) The location of the building in relation to other buildings, public places and natural hazards;
- (d) The intended life of the building;
- (e) How often people visit the building;
- (f) How many people spend time in, or in the vicinity of the building;
- (g) The intended use of the building; including any special traditional and cultural aspects of the intended use;
- (h) The expected useful life of the building and any prolongation of that life;
- (i) The reasonable practicality of any work concerned;
- (j) In the case of an existing building, any special historical or cultural value of that building; and
- (k) Any other matter that the territorial authority considers to be relevant.

It should be noted that in relation to the above, under section 34 (7) of the Building Act a Territorial Authority has no powers to waive or modify the access requirements.

C3.1 Cost

The Territorial Authority, in deciding what is reasonably practicable, under sections 38 and 46 must have regard to all the circumstances.

If for example one of the grounds for seeking lesser provisions is that it will be unreasonably costly to comply in all respects with the requirements of section 47A, the circumstances that the Territorial Authority should take into account in reaching a decision could include:

- (a) The need to offset the benefits of full compliance against the costs of such compliance, i.e. the installation of a lift adds to the value, the economic viability, the usefulness and convenience of a building. The construction of ramps, both internal and external, can have a similar effect by providing, for example, usable goods trolley routes;
- (b) The extent of the structural alterations which may be needed to install a lift, and the ways in which these costs may be lessened;
- (c) The possibility of combining a goods and passenger lift.

It should be noted that all of the above does not consider any general costs savings to the community that the access requirements may have in enabling people with disabilities to enter employment when they would otherwise be on a benefit.

There is also no consideration given to any savings in accident and injury costs from the potentially safer built environments that may result from good implementation of access requirements.

Recognition of a building as an 'historic building' may be obtained via the New Zealand Historic Places Trust or as a listing in the district plan by the local authority.

C4 Entrances (refer to 7.1.1)

Alternative entrances at the back or side of a building shall be acceptable provided they are located on an accessible route from the car park and have a direct connection to the internal space served by the main entrance.

When an alternative entrance to a building for people with disabilities is not immediately obvious then a sign giving direction to the alternative accessible entrance shall be installed at the main entrance.

C5 Doorway in corridor wall (refer to 7.3.4.1)

The clear width of doorways is governed by the existing circulation space, i.e. the width of the corridor. The following table C1 shows the increased door width required with narrower corridors such as may be found in existing buildings.

Table C1 – Clear width of doorway

Existing circulation space (mm) – A	Doorway clear opening (mm) – B
900	1200
1000	1000
1200	760

Figure C1 illustrates the table C1 dimensions.

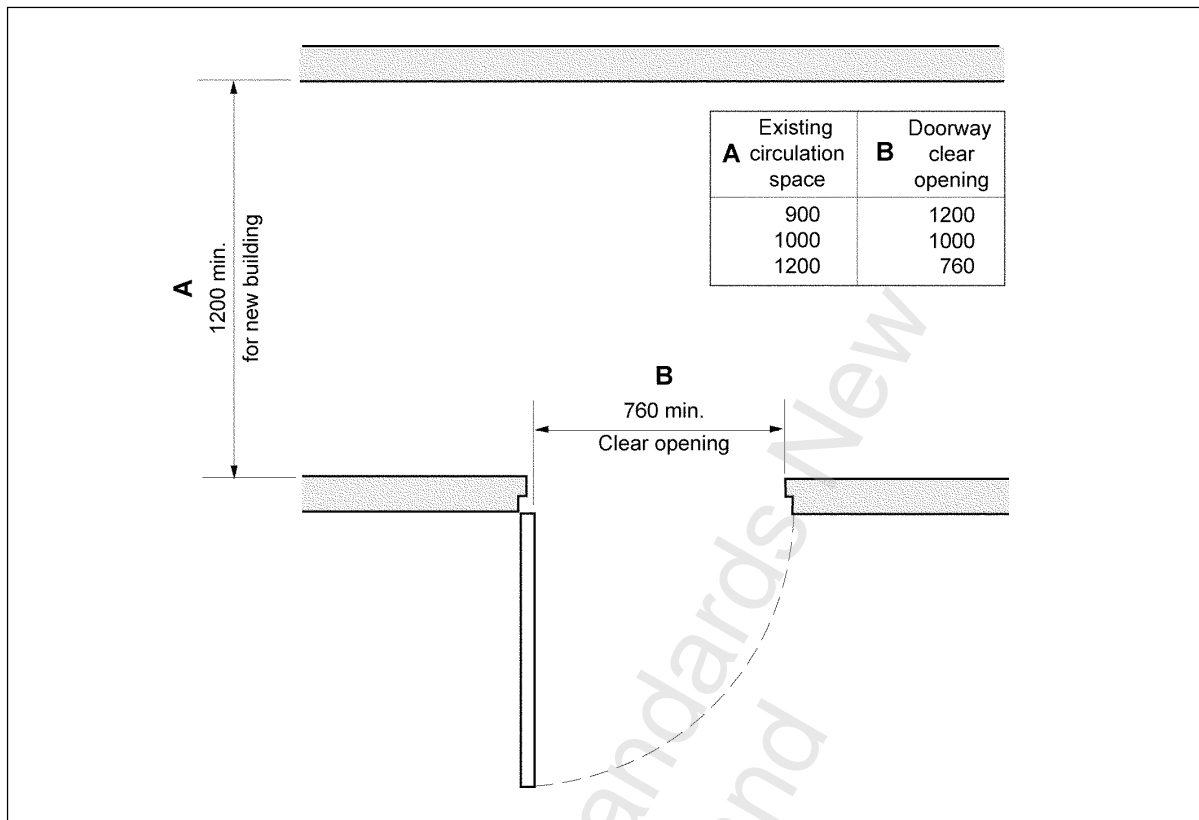

Figure C1 – Doorway width for narrow corridors

CC6.2

Controls are preferred on both sides of the lift as there is no room to manoeuvre a wheelchair once it is in the car.

CC6.3

Wherever practicable, with reduced-size lifts, consideration should be given to providing more than one entry/exit from the lift car.

C6 Lifts (refer to 9.2.2.1)

This clause provides for the circumstances under which smaller lifts may be installed or continue to be used in existing buildings. It applies when it is not reasonably practicable to comply with the lift requirements of 9.2.2.1.

C6.1 Reduced lift car size

Two sizes are given:

- (a) For use by a wheelchair user alone, the lift car shall be at least 900 mm by 1400 mm.
- (b) A car size of 900 mm by 1575 mm allows room for a person accompanying and will accommodate some scooters.

C6.2 Controls

When C6.1 is used the operating controls shall be placed in the centre of the lift sidewall.

C6.3 Doors

Reduced-size lifts shall be fitted with a power-operated door, at least 900 mm wide and opening in the narrower dimension of the lift car.

C6.4 Enclosure

Reduced-size lifts shall be enclosed on all four sides.

C6.5 New Zealand Building Code requirements

All lifts shall comply with NZBC D2/AS1.

C7 Vertical platform lifts**C7.1**

Powered lifting platforms shall comply with BS 6440. Platform lifts shall not be used as an alternative to the requirements of 7.1.3 (i.e. main entrances shall preferably have a flat access but may be ramped).

C7.2

BS 6440 covers the transportation of people with disabilities between fixed levels in which the maximum height of the platform above the lowest level in public buildings does not exceed:

- (a) 2.0 m when there is no liftway enclosure or floor penetration;
- (b) 4.0 m when the liftway is enclosed.

These types of lifts may be installed to enable people with disabilities to reach a stage in a hall etc.

C8 Stair-lifts

Stair-lifts shall not be used as a means of complying with access requirements for reasons given in CC8. However, they may be considered for use in private dwellings – such stair-lifts shall comply with BS 5776.

CC8

Stair-lifts are a mechanical means of ascending and descending stairs. The stair-lift track is either fixed to the stairs or to the wall side of the stairway. A stair-lift either has a chair or wheelchair platform and is usually operated by the occupant.

People with disabilities generally avoid using stair-lifts in public, because they attract attention when being operated. They are seen by many as a “special provision for the disabled” and they can impede the other users of the stairs.

Stair-lifts are ideal in private dwellings but should not be considered in public places for the following reasons:

They are in conflict with this Standard which requires handrails on both sides of the stair;

The stair track reduces the available width of stair – as most stairs are incorporated into a means of egress, this will cause a hazard;

Stair-lifts are prone to vandalism and abuse in public spaces;

Preventative maintenance programmes are required by section 44(j) of the Building Act but are often not implemented.

Where the stair-lift has a chair, a wheelchair user is required to transfer from the wheelchair to the chair and the wheelchair would then have to be carried by an attendant to the next level.

For a person with arthritis, stroke, angina etc., using a stair-lift with a wheelchair platform would be unwise, as the person would be required to stand on the platform without the support of a handrail.

Stair-lifts and inclined railways are subject to local authority permit application and any approval procedure.

CC9.1

This could be done by combining two standard toilet compartments into one by removing the common partition, creating one toilet pan and fittings as shown in figure C2.

Many existing toilet cubicles are difficult for people with disabilities to enter and use because of the position of the door and the fact that it opens inwards. Often this situation can be overcome by the simple expedient of re-hanging the door so that it opens outwards.

Inward-opening doors can work effectively if there is a turning circle space of 1500 mm diameter beyond the open door.

Other problems include toilet vestibules with double doors that can be difficult to negotiate and may trap a wheelchair between the doors.

CC9.2

Insufficient door widths may be improved by using swing-clear hinges. Also consider using sliding doors.

CC10

It is possible to adapt existing handrails by changing their fixing or by providing a new handrail that is easily grasped by people with disabilities, see figure C3.

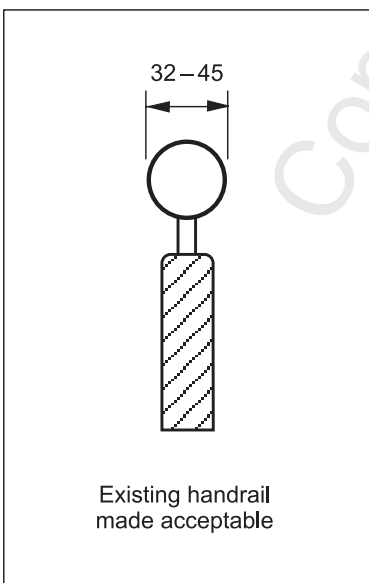

Figure C3 – Handrail adaptation

C9 Toilets

C9.1 Compartments

Existing toilet compartments shall be modified so as to be accessible to people with disabilities (refer 10.5).

C9.2 Door widths

Door widths shall be widened whenever possible to provide a minimum clear opening of 760 mm (refer to C5).

C10 Handrails (refer to 6.4, 6.5, 8.6)

The requirements for handrails and grab rails shall apply to altered buildings.

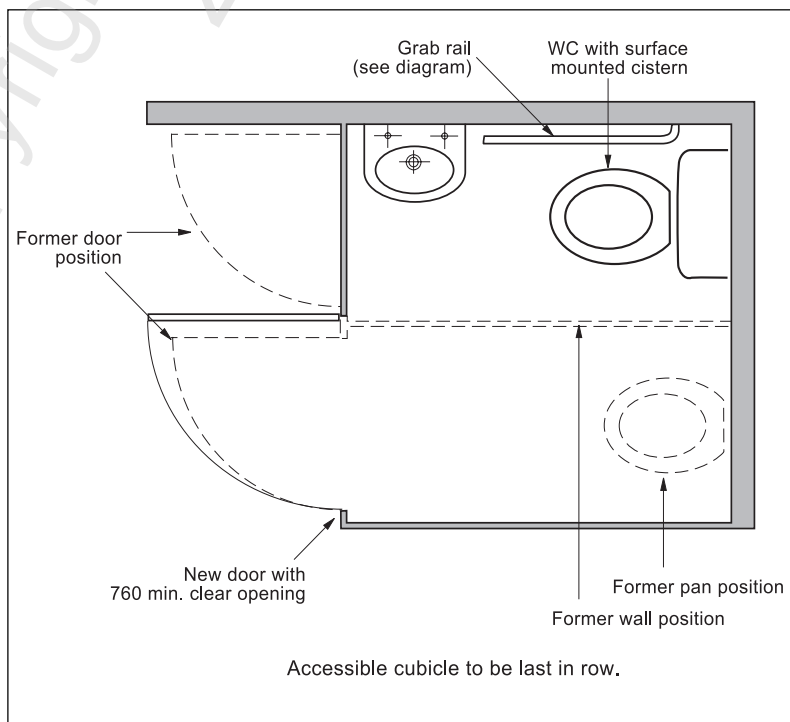

Figure C2 – Toilet compartment in existing building

APPENDIX D PEOPLE WITH DISABILITIES – MOBILITY AND MOBILITY AID INFORMATION

(Informative)

D1 Scope

This Appendix presents information and data associated with people with disabilities and their aids to mobility that affect the design of buildings, travel along an accessible route and the use of furniture and fittings.

D2 General

This Appendix is designed to provide information to help designers, builders, building officials etc. to appreciate the main problems met by people with disabilities and to give background to the requirements of this Standard.

D3 People with disabilities

D3.1 Ambulant

D3.1.1 Clear width

People who are ambulant with mobility aids need a clear width of 1000 mm.

D3.1.2 Walkers

Walkers and walking frames are produced in many variations with bases consisting of a combination of feet, wheels and castors. In general these have a 590 – 700 mm base width.

D3.1.3 Steps

The 180 mm step rise shown in figure 25 is on the high side for the comfort of the majority of people with disabilities.

Records show that more accidents occur while going down stairs, and studies have shown that a 310 mm tread provides increased safety during descent of the stairs.

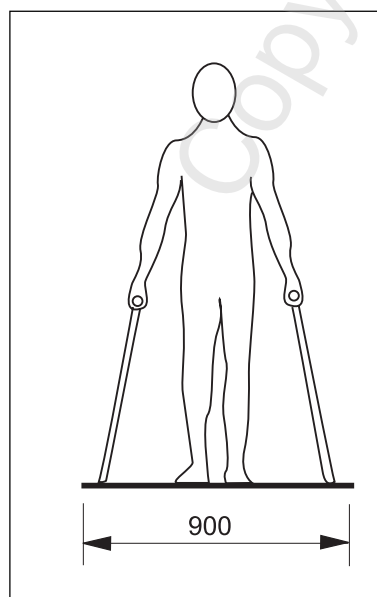

Figure D1 – Crutches

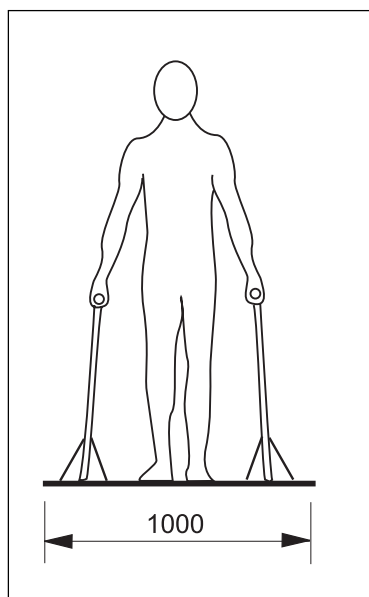

Figure D2 – Tripods

The optimum dimension of 310 mm tread with 150 mm risers gives a smaller rise and increased tread and adds to comfort and safety.

D3.1.4 Handrails and grab rails

D3.1.4.1 Height

Stair research has established that for young adults and elderly stair users alike, higher handrails are more useful, the best performance by both population groups occurred with heights between 915 mm and 965 mm at all stair slopes measured from the pitch line. The average preferred handrail height for young and old subjects alike was 927 mm.

D3.1.4.2 Shape

A graspable handrail requires contact of the rail with at least 80 mm of the hand measured from the top knuckle of the index finger around to the thumb, refer NZBC D1/AS1 figure 26. This represents a grip of 270° around the rail. The profiles of handrails and grab rails in Appendix F are derived from this requirement.

D3.2 Sight impairment

D3.2.1 General

Sight impairment ranges from focussed vision but for only part of the field of view, through blurred vision where detail merges with the background, to total loss of sight.

D3.2.2 Clear width

People with a visual impairment using mobility aids need a clear width of up to 1200 mm.

Passage widths for people who are blind or partially sighted

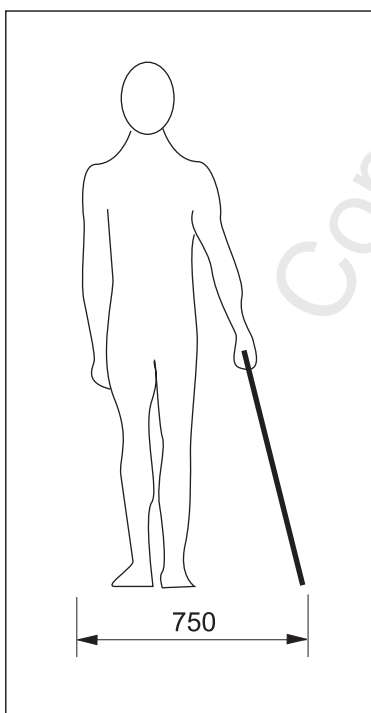

Figure D3 – White cane

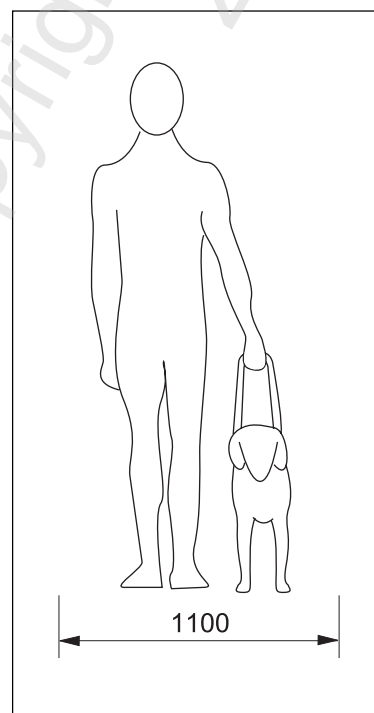

Figure D4 – Guide dog

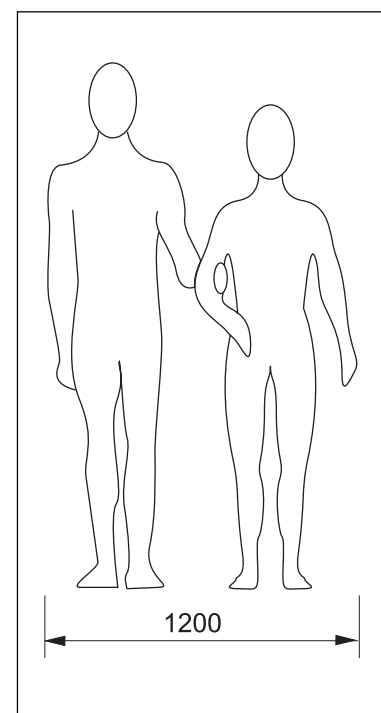

Figure D5 – Sighted guide

D3.2.3 Colour and contrast

Good contrasting visibility characteristics aid partially sighted people. The contrast may be by use of colour at the change of plane on an object, e.g. a bench top, back and front lip or change in stair-nose colour, by change in pattern on a surface, or by use of illumination.

D3.2.4 Contrast through illumination

Good distinction between features on an accessible route or in accessible accommodation can be obtained by using natural or artificial light. A luminance factor difference between an object or surface and its surroundings of 0.3 is recognized as being needed.

It is important that all fittings, e.g. electrical, door controls, sanitary fittings etc. contrast with their surroundings.

D3.2.5 Tactile and audible cues

People with vision impairments also rely on tactile cues, a change in surface texture, to indicate a major change in the accessible route. Examples are the nosings on stairs and the use of tactile ground surface indicators, both indoors and outdoors.

Coincident with the installation of tactile cues, a change of material will also provide audible cues e.g. a change from concrete to rubber, carpet or timber.

D3.2.6 Guide dog run

Where a guide dog run may be required, a suggested layout is shown in figure D6.

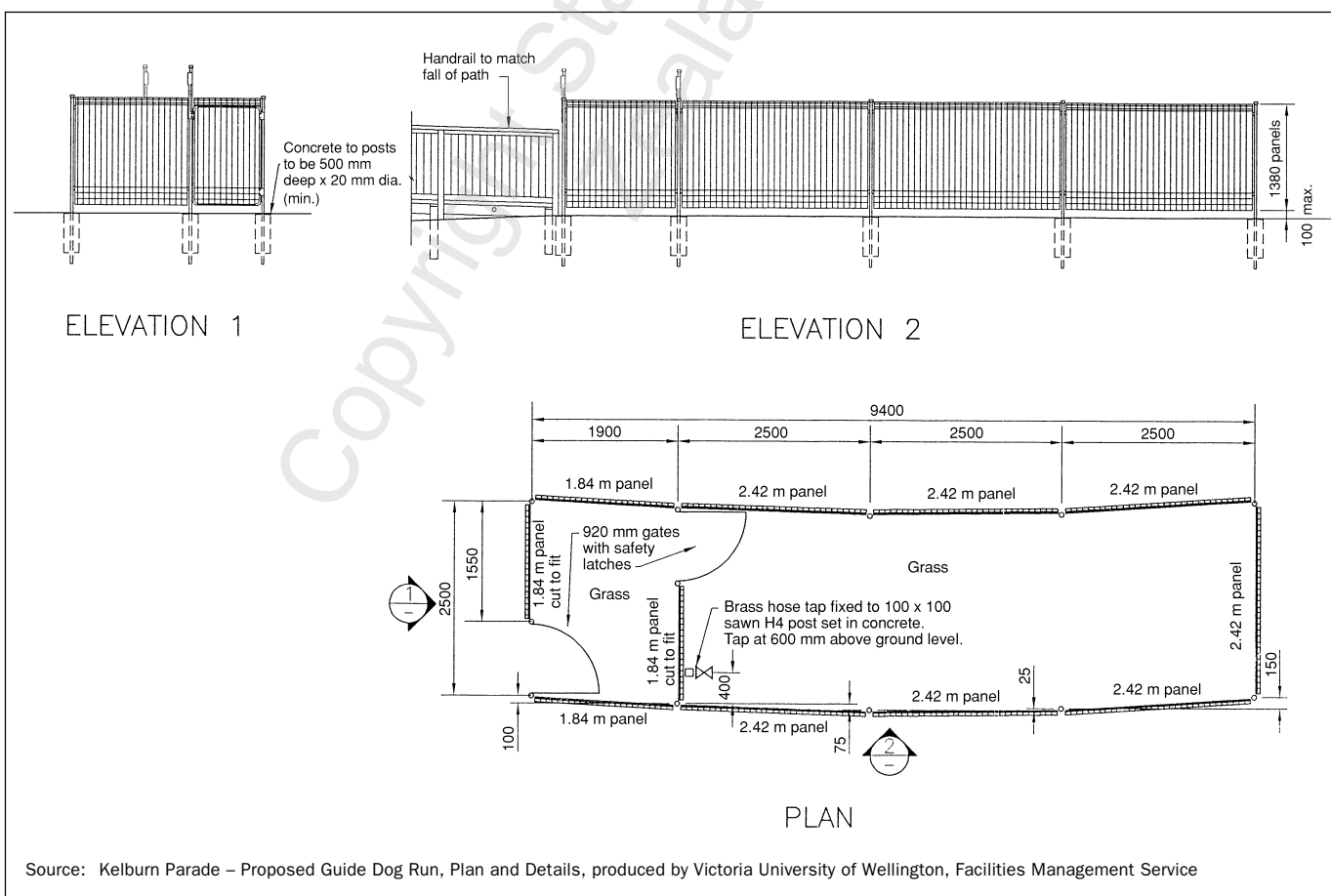

Source: Kelburn Parade – Proposed Guide Dog Run, Plan and Details, produced by Victoria University of Wellington, Facilities Management Service

Figure D6 – Guide dog run

D3.3 Wheelchairs

D3.3.1 General

Wheelchairs are either pushed by an attendant manually, self-propelled by the owner or motorized. The motorized wheelchair is powered by batteries which are usually charged overnight and, which vary the wheelchair dimensions and weight from a standard manual wheelchair.

D3.3.2 Size

Average unoccupied motorized wheelchairs/scooter sizes (NZ) are given in table D1, for a seat width average of 450 mm. This Standard recommends a basic 1500 mm turning circle to cover most wheelchairs, however, a turning circle of 1985 mm is recommended wherever there is heavy use of motorized scooters.

Table D1 – Average dimensions of motorized wheelchairs and scooters (unoccupied)

	Overall width	Length	Seat height
Motorized	600 – 760	1000 – 1130	460 – 530
Scooter	610 – 650	1120 – 1600	–

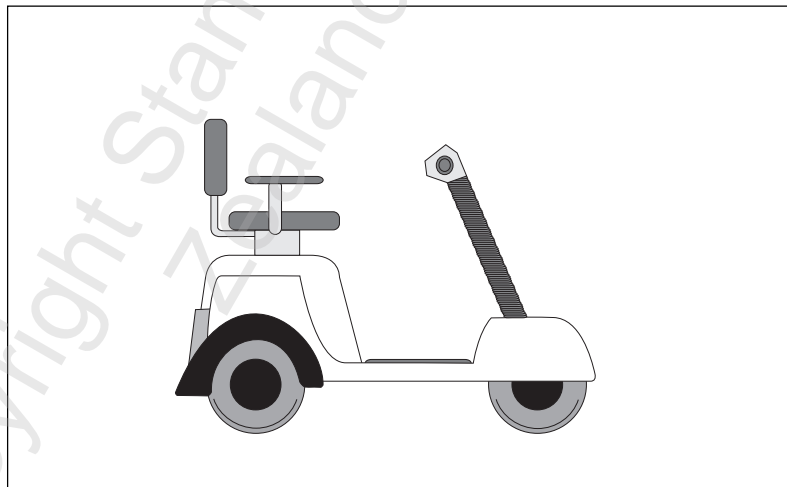

Figure D7 – Basic scooter profile

D3.3.3 Other dimensions

Other dimensions associated with wheelchairs are illustrated in figure D8.

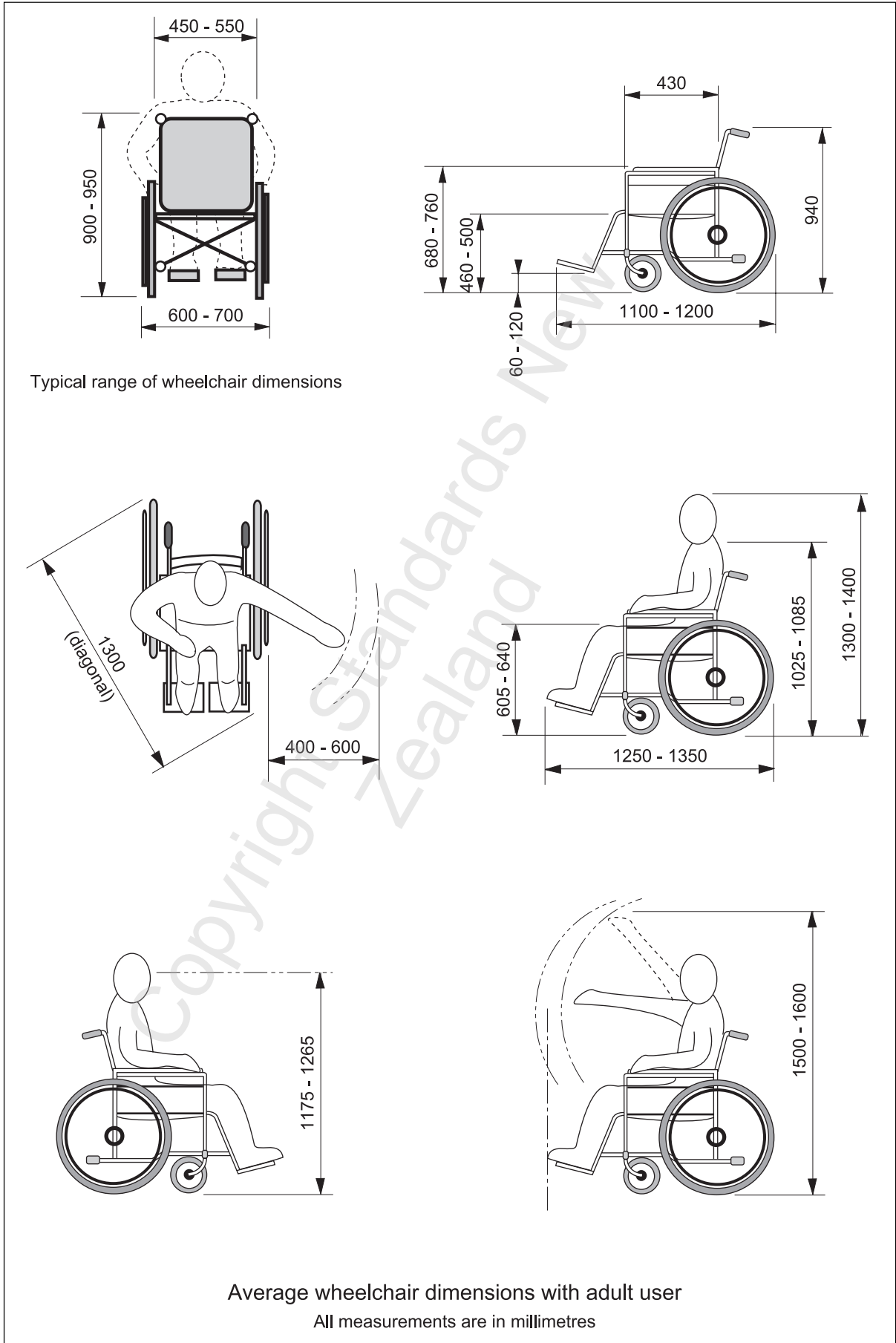

Figure D8 – Typical wheelchair dimensions

D3.3.4 Minimum clear floor space

The minimum clear space required to accommodate a single stationary wheelchair and occupant is 800 mm x 1300 mm, see figure D9.

D3.3.4.1 Clear width

A minimum clear width of 1200 mm is required on an accessible route, this allows for a person in a wheelchair to pass a person walking. For two wheelchairs to pass a space of 1800 mm is required, see figure D10. Alternatively a passing arrangement as shown in figure D11 is possible.

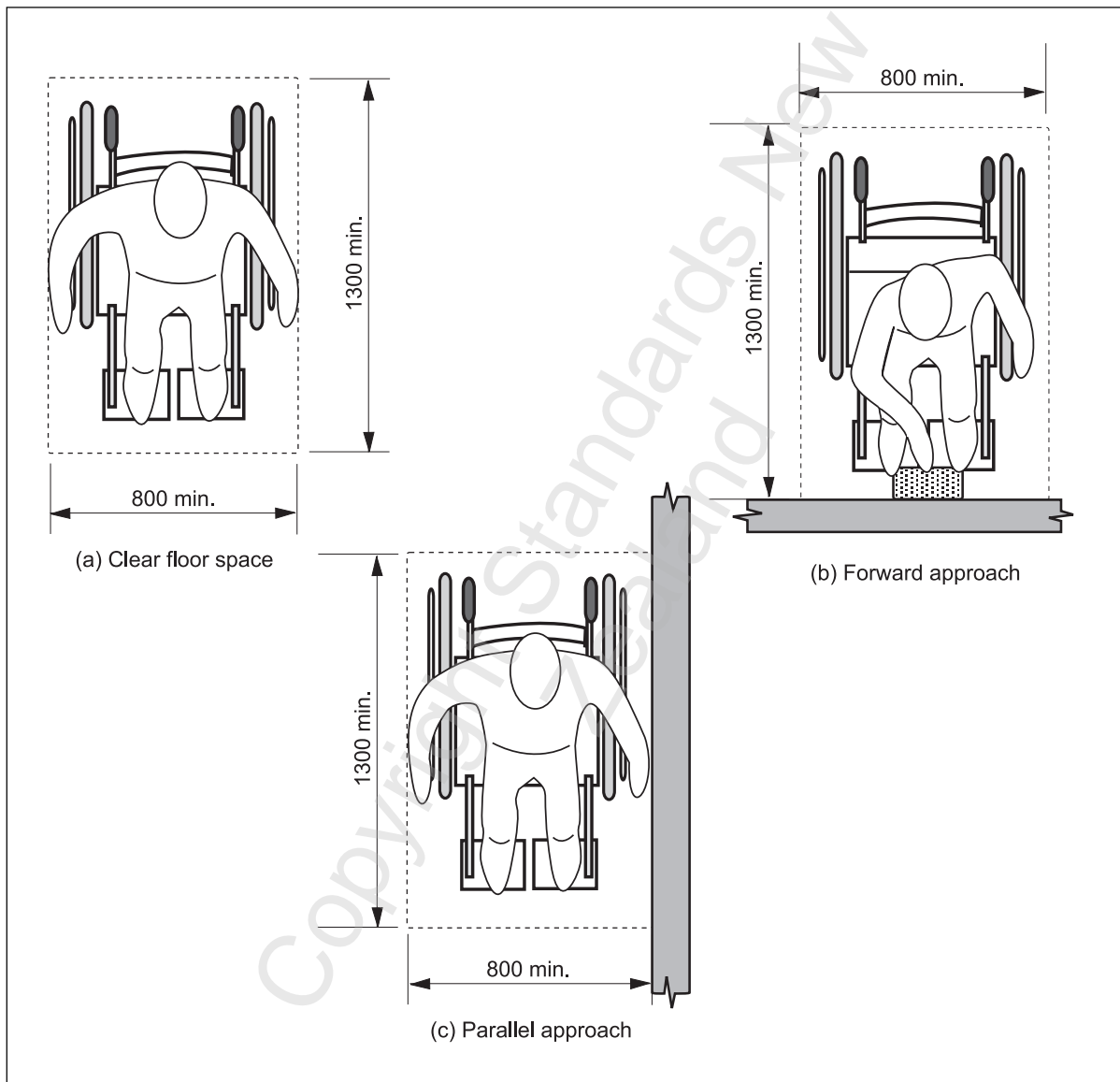

Figure D9 – Minimum clear floor space

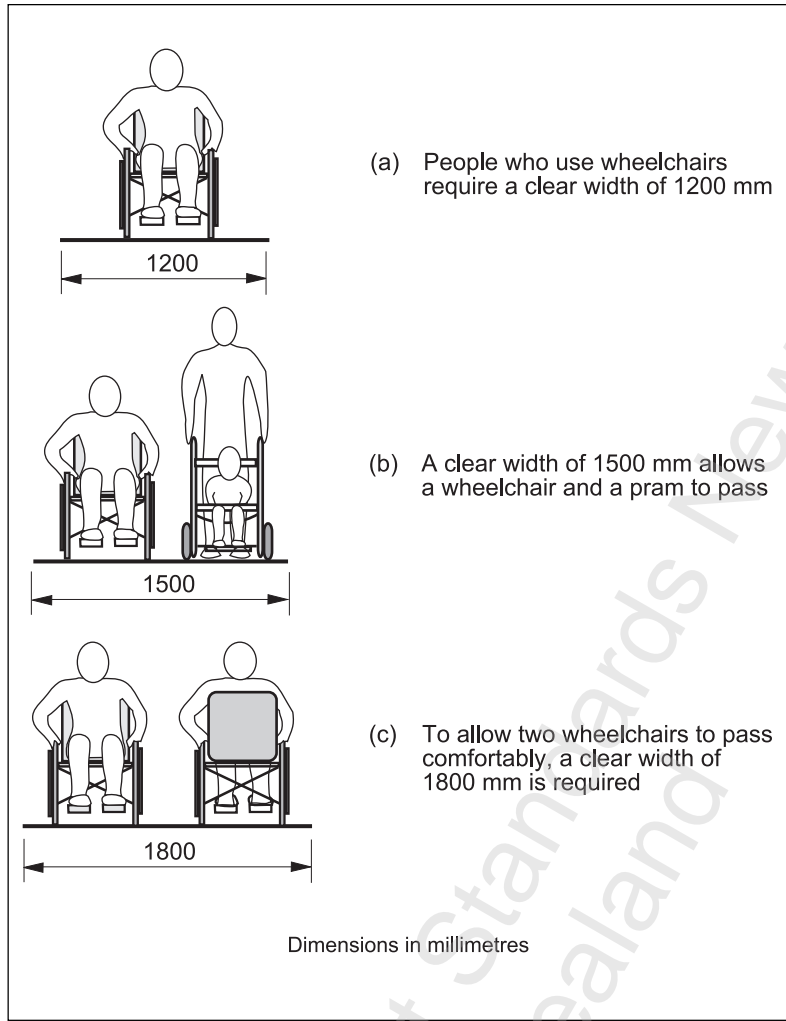

Figure D10 - Clear widths

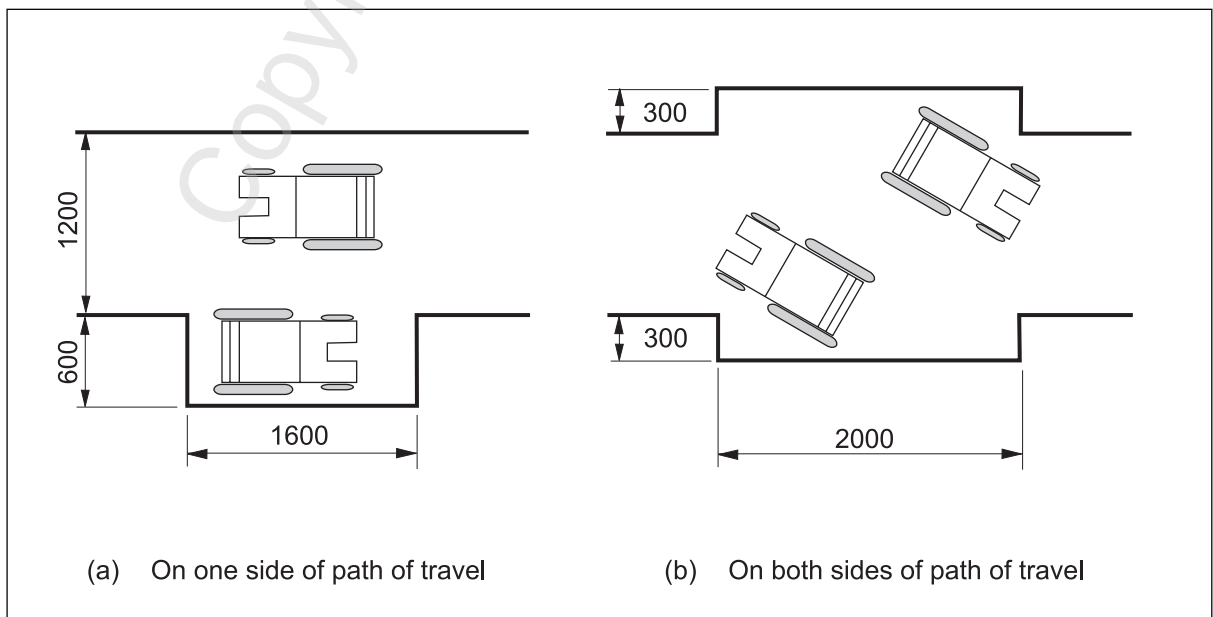

Figure D11 - Passing space for wheelchairs

D3.3.4.2 Turning space

The corridor dimension of 1200 mm used in this Standard is a minimum dimension and relies on additional turning space available at the clear openings of doorways and at open plan and widened corridor areas. From time to time in this Standard, 1500 mm is indicated as a minimum turning circle dimension.

A full 360° turn space of 1950 mm x 1950 mm is required for most motorized scooters.

Distances required for wheelchair manoeuvrability between tables and chairs are shown in figure D12.

D3.3.5 Reach

The reach possible from a wheelchair is shown in figures D13 to D17. The reach for people with ambulant disabilities is shown in figure D18.

D3.3.6 Viewing range

The height zone for comfortable viewing is shown in figure 5. This height zone has been computed from the averaged eye height of tall males and short females standing, and the average height of people seated in wheelchairs.

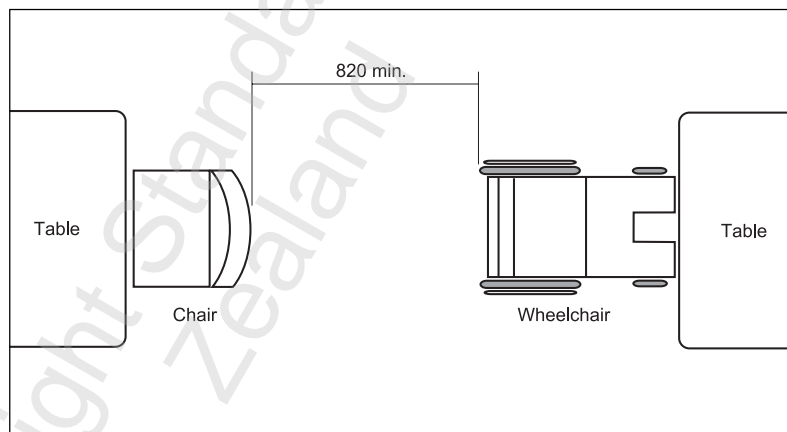

Figure D12 – Distance between tables and chairs

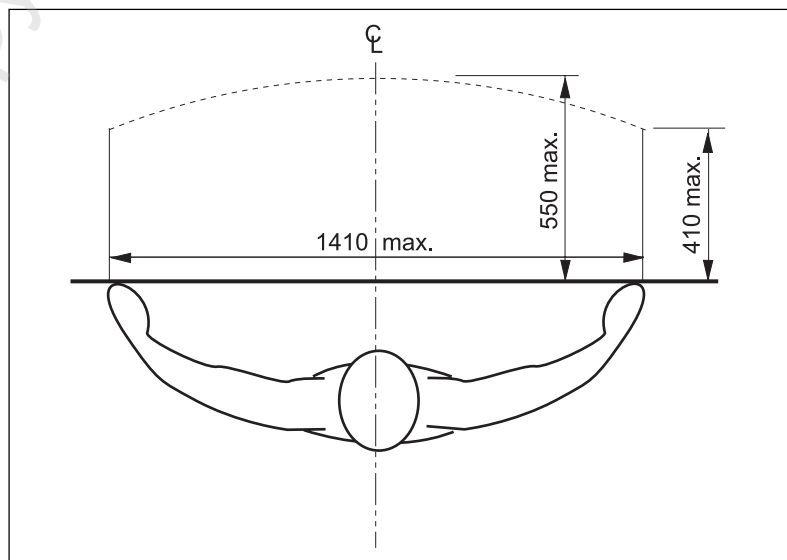

Figure D13 – Maximum horizontal reach to objects on table or bench tops

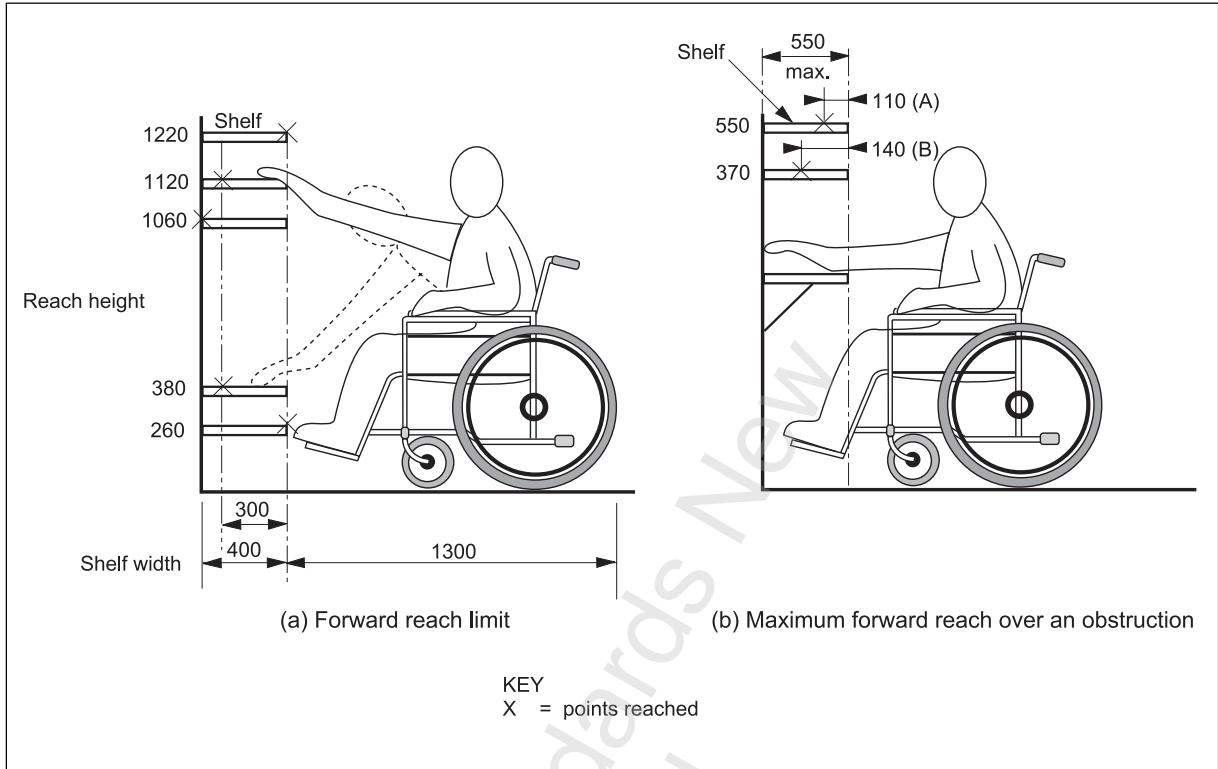

Figure D14 – Forward reach from a wheelchair

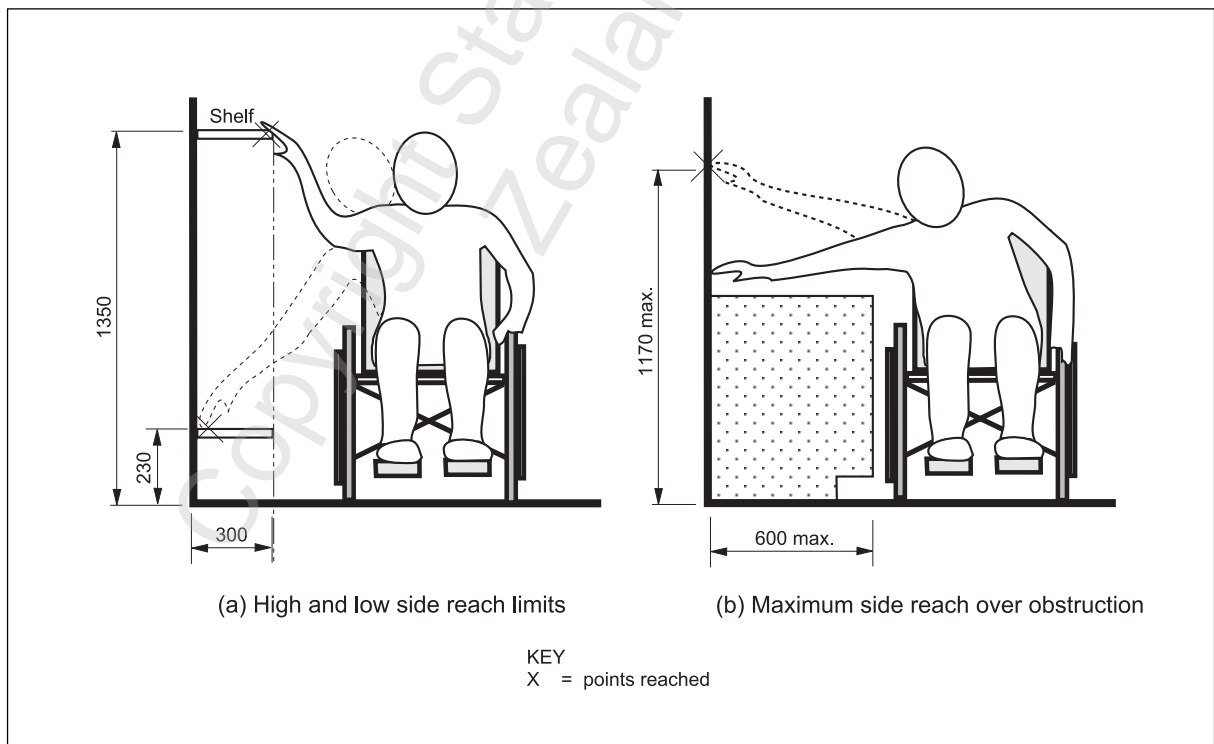

Figure D15 – Side reach from a wheelchair

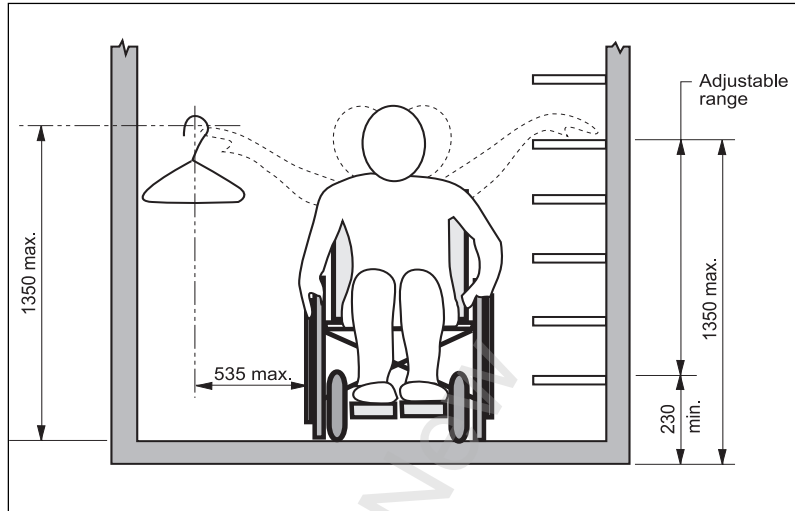

Figure D16 – Storage shelves and wardrobes

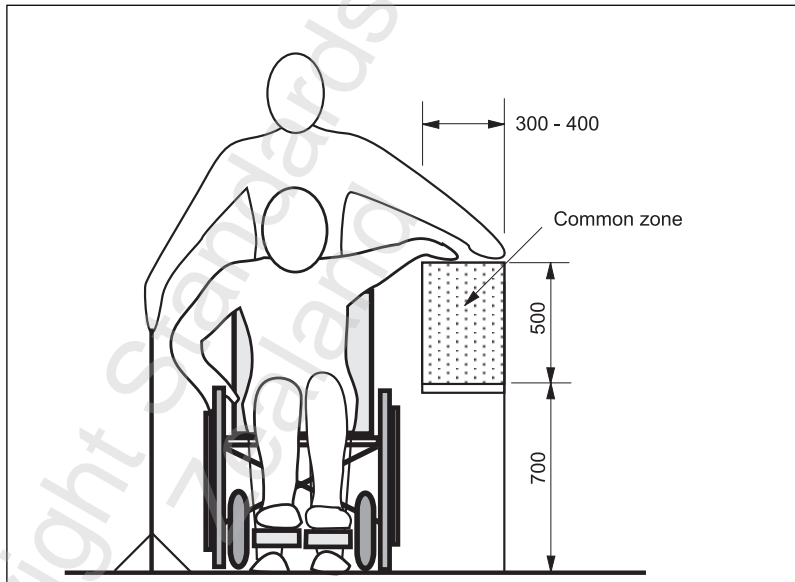

Figure D17 – Area of common reach for ambulant people with disabilities and wheelchair users

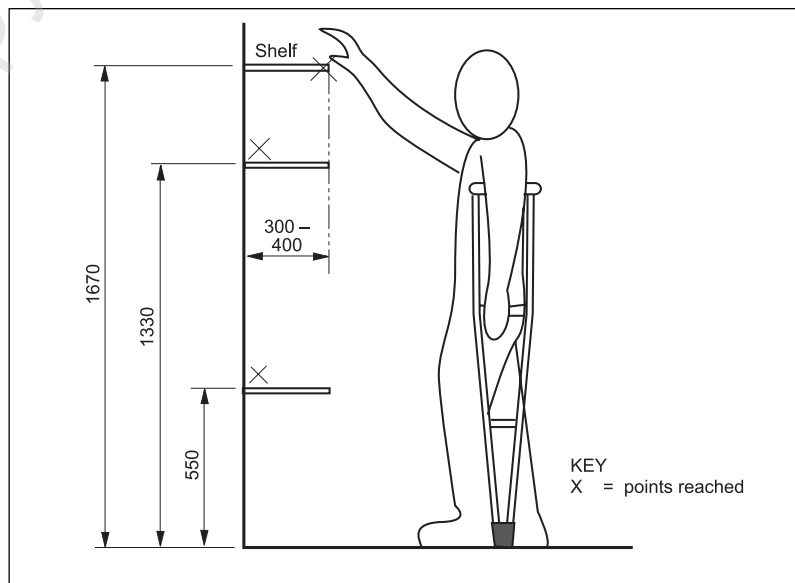

Figure D18 – Ambulant reach

**APPENDIX E
INTERNATIONAL SYMBOLS
(Normative)**

E1 Scope

This appendix covers the requirements for the production of the international symbols for access and for deafness.

E2 International symbol for access

E2.1 Layout

The proportional layout of the symbol for access shall be in accordance with figure E1.

E2.2 Colour

The colour of the figure shall be white on a blue background. The blue shall be 'Safety blue' BS 5252 Colour No. 18E53. However, other colours may be used to "fit" with the decor, provided there is a colour contrast between the symbol and its background.

E2.3 Use

The international symbol for access is used to identify buildings and facilities that are fully accessible in the terms of this Standard or the NZBC. It is also used on signs to indicate the direction of an accessible facility such as a car park or toilet.

For signs identifying a facility, the figure shall face to the right. For indicating the direction to a facility, the figure shall face in the direction to be indicated (see figure 3).

CE2.3

The sign can be used either with or without the directional arrow.

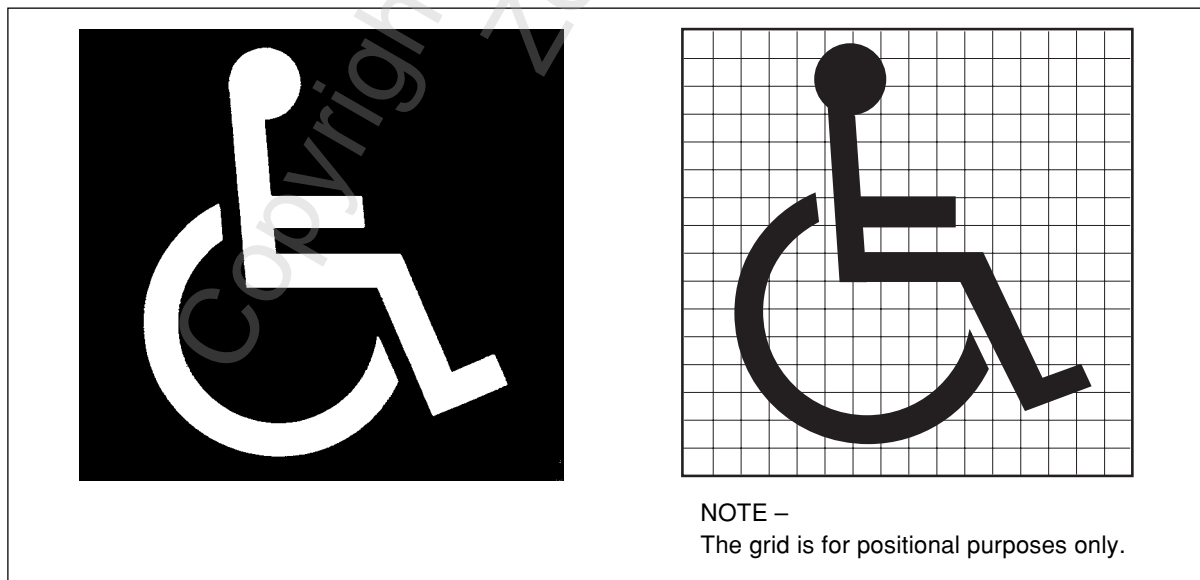

Figure E1 – International symbol for access

E3 International symbol for deafness

E3.1 Layout

The proportional layout of the symbol for deafness shall be in accordance with figure E2.

E3.2 Colour

The colour of the figure shall be white on a blue background. The blue shall be 'Safety blue' BS 5252 Colour No. 18E53. However, other colours may be used to "fit" with the decor, provided there is a colour contrast between the symbol and its background.

E3.3 Use

The international symbol for deafness is used to indicate that aids are available to help the deaf, e.g. hearing augmentation – listening system.

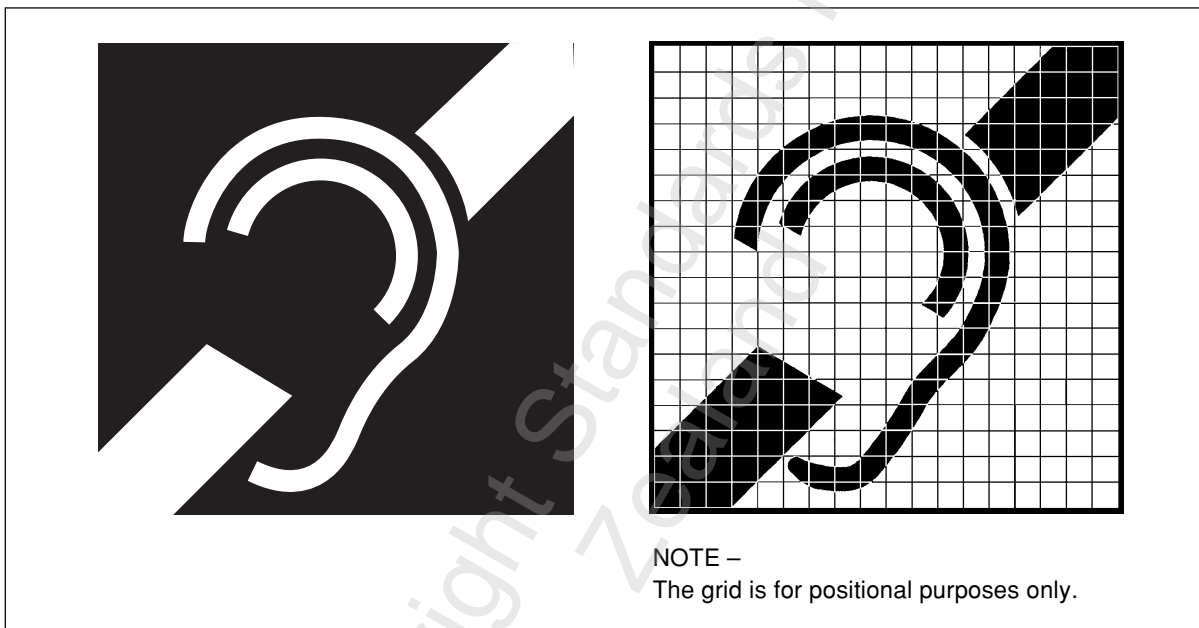

Figure E2 – International symbol for deafness

APPENDIX F HANDRAILS AND GRAB RAILS

(Normative)

F1 Scope

This Appendix describes the type and basic installation requirements for handrails, lift support rails and grab rails as used in this Standard.

F2 General

Handrails and grab rails serve different functions. A handrail is used as a guide for general support and to occasionally take full weight both in regular use and for accidental slip, trip or stumble. A grab rail is usually of smaller diameter and is more often used to take the full weight of a person with a disability. Full weight is applied both as a direct downwards force, e.g. in maintaining balance, and as a leverage force e.g. when lifting the body.

Many people brace their forearms between a rail and the wall to give them more leverage and stability.

F3 Handrails

F3.1 Shape

F3.1.1 Length

A handrail shall be continuous along the length of a ramp or staircase, except when there are doorways opening off a landing.

F3.1.2 Grip shape

The handrail shall be rounded with an outside dimension of between 32 mm and 45 mm and shall provide a secure grip, see figure F1. The ideal handrail is a circular section.

F3.1.3 Obstructions

There shall be no obstruction to the movement of the hand along the length.

F3.1.4 End of handrail indicator

A domed button to indicate the imminent termination of the rail shall be fixed at 150 mm from the end of the rail (see figure 23).

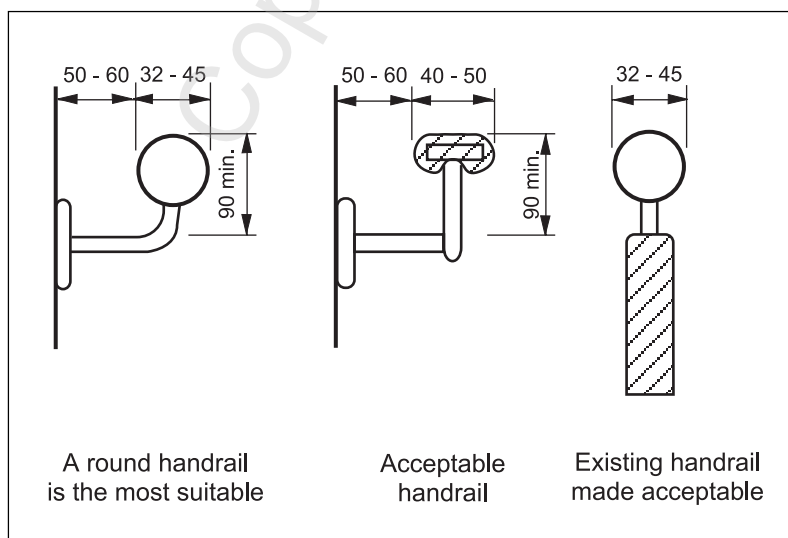

Figure F1 – Handrails

CF5.2

Highly polished surfaces provide insufficient grip.

F4 Installation of handrails**F4.1 Clear length**

Handrails shall be installed so that there is a clear space of 50 – 60 mm between the handrail and the wall for its full length.

F4.2 Stairs, ramps etc.**F4.2.1**

The handrail shall extend past the start and finish of the stairs or ramp by at least 300 mm (see figures 22 and 23).

F4.2.2

Handrails shall be installed at the height required by this Standard, refer to 6.4.2.6 and 8.6.

F5 Grab rails**F5.1 Shape**

Grab rails shall allow an opposing grip by the full hand and shall be of circular section of 30 – 40 mm, see figure F2.

F5.2 Grip

The surface of grab rails at the point of use shall be non-slip.

F6 Installation of grab rails**F6.1 Clear length**

Grab rails shall be installed so that there is a clear space of 50 mm minimum between the rail and the wall for the full length.

F6.2 Installation

Grab rails are primarily intended for use in toilets, showers and bathrooms, refer to section 10.

F7 Load-bearing test for handrails and grab rails

Handrails and grab rails and the method of fixing to their support shall be capable of sustaining a force of 1100 N (110 kg) applied in any direction at any point. The force shall be applied for a period of 2 minutes after which there shall be no sign of fracture of the fixings points nor shall there be deformation greater than 5 mm. With the force removed, there shall be no permanent deformation greater than 1 mm.

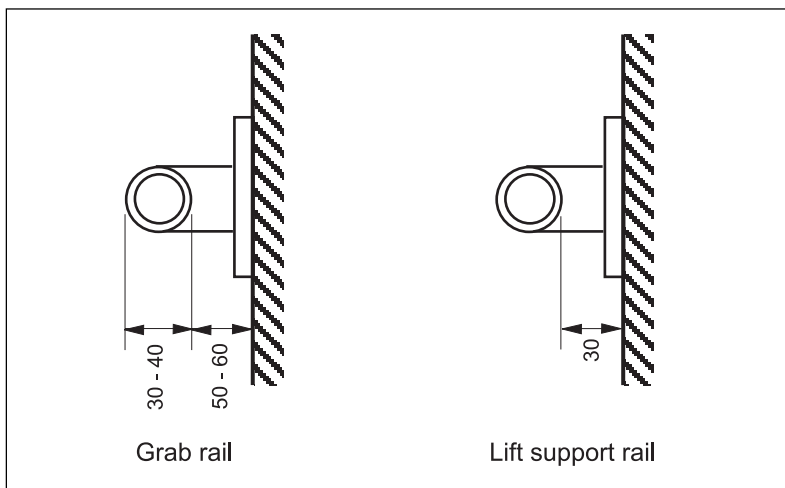

Figure F2 – Size and spacing of a grab rail

APPENDIX G SCISSOR STAIRS

(Informative)

G1 Scope

This Appendix gives an example of a service core plan with scissor stairs.

G2 General

Figure G1 shows an example of a plan of service core to a building with scissor stairs. This is a common design of stair in public buildings. Various design features should be noted.

The centre partition wall requires a continuous handrail around it at each landing which coincides with a floor level, refer to 8.3.

The projection of the handrail into the landings at the points shown in figure G1 still permits, if necessary, a wheelchair to turn through 180° by allowing its footrests to pass under the handrail.

The centre partition is not required to extend into the landing area. The handrail may be positioned as shown in figure G1 provided that it does not intrude into the landing by more than the going.

Scissor stairs shall have mid-flight landings at a height of 2500 mm maximum (refer to 8.3.6).

When the doors to the toilet facilities open off the landings at floor levels and these levels form part of the corridor system in the building, it is preferable that the landings are wide enough to enable a wheelchair to turn through 360° at the positions shown in figure G1. A landing width in excess of the minimum of 1200 mm is required by this Standard and is recommended to enable a wheelchair user to open and close doors off landings, including fire doors.

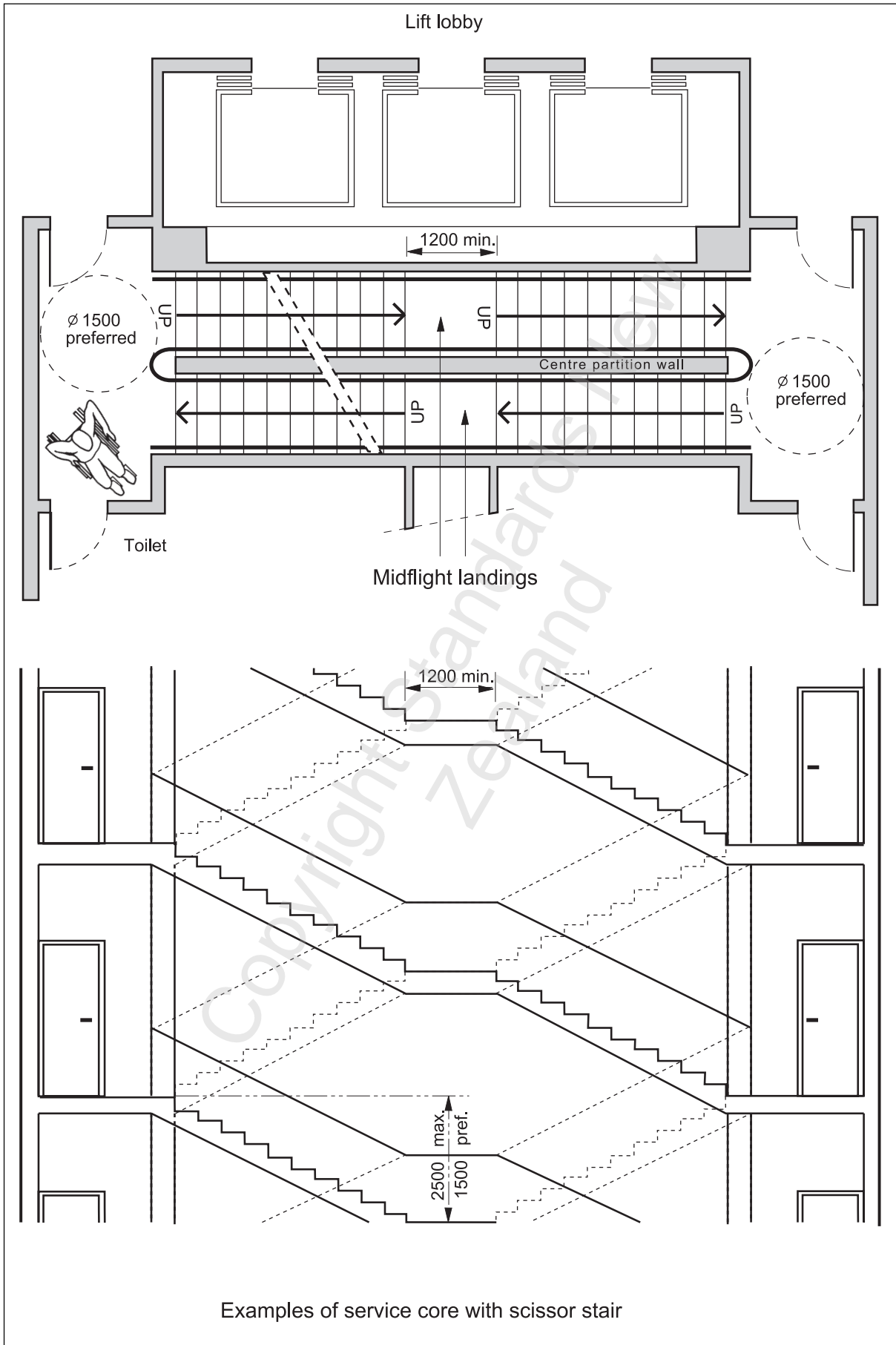

Examples of service core with scissor stair

Figure G1 – Scissor stair design

APPENDIX H HEARING AUGMENTATION – LISTENING SYSTEMS

(Informative)

H1 Scope

This Appendix provides informative information on listening systems.

H2 General

When choosing a listening system the following considerations apply:

- (a) The system needs to be usable by people who do not have hearing aids and by people who:
 - (i) Have hearing aids with a “T” switch
 - (ii) Have hearing aids with audio input
 - (iii) Have hearing aids without a “T” switch or audio input.
- (b) The frequency response and the adjustable volume gain of the receivers needs to be suitable for people with varying severity of hearing impairment;
- (c) It is essential that the equipment provided is safe and easy to manipulate and that the hygiene of reusable ear-pieces on receivers can be ensured;
- (d) The system chosen needs to be suitable for the intended use and not be subject to interference from, or cause interference to, any other equipment. For example, audio-loops may be subject to interference from nearby electrical installations; radio-frequency transmissions may interfere with other transmission on similar bands; strong lighting may interfere with infrared transmission.
- (e) It is essential that the system does not interfere with the listening enjoyment of others, e.g. sound leakage from headphones;
- (f) Where privacy is required, as in courtroom proceedings, infrared transmission is suitable because it will not pass through walls.

H3 Listening systems

Acceptable types of listening systems include audio-frequency induction loops, FM radio-frequency transmission, infrared systems or similar.

An induction loop system must include any necessary microphones and amplifiers in addition to the wired loop.

Other types of listening systems must include appropriate transmitters and receivers.

H3.1 Audio-frequency induction loop systems

People using hearing aids that are fitted with a magnetic induction coil can directly receive the audio-frequency induction loop system. This is a standard hearing aid option. The recommended magnetic field strength, as specified in AS 1088.4, is 20 ± 3 dB relative to 1 ampere per metre for an input signal of level equal to the long-time average level of input speech. This field was chosen so that it is high enough to produce an acceptable signal-to-noise ratio over environmental electromagnetic noise for power

installation and the like, yet not so high as to cause overloading of hearing aids.

The audio-frequency induction loop system cannot be used successfully in multiple installations close together, e.g. in adjacent rooms, owing to mutual interference resulting from spill-over of the magnetic field outside the looped area, both vertically and horizontally.

H3.2 Infrared light transmission systems

In this system, a modulated light beam is transmitted to special receivers worn by the listeners. The line of sight from transmitter to receivers must be unobstructed. The system may become inoperative when the receivers are exposed to direct sunlight.

It may be used as an alternative to the audio-frequency induction loop system when multiple room installations are required to operate simultaneously.

H3.3 The VHF frequency-modulated radio system

Unlike the induction field radio system this system operates in the very high frequency (VHF) band, where a number of channels for use by hearing impaired people have been allocated by the ITU. It can therefore make use of different channels to avoid mutual interference when a number of transmitters have to be used in one building.

Because of the short wavelength used, the received field strength reduces slowly as the distance from the transmitter increases. Potentially it has greater range than the induction field radio system. The system needs an external antenna that is short enough to be carried on the person. On the other hand, induction field radio systems use loop antennae mounted internally in the receiver.

H3.4 Induction field radio system

The induction field system is a frequency-modulated system normally operated on a carrier frequency of 3175 kHz allocated by the International Telecommunications Union (ITU). This allocation is shared by other radio services, which may occasionally interfere.

The basic feature of the induction field radio hearing aid system is its localised wireless transmission in which the induction field is strong near the transmitter but rapidly becomes weaker with increasing distance; a low power battery-operated version is limited to a range of about 12 metres. When several systems are in use in a confined area, the receiver responds only to the strongest signal.

This system is particularly useful when the speaker, wearing a portable transmitter and associated microphone, must move about in company with the listeners, for example on guided tours in museums and art galleries.

Copyright Standards New
Zealand

© 2001 STANDARDS COUNCIL

Approved by the Standards Council on 27 November 2000 to be a standard specification pursuant to the provisions of section 10 of the Standards Act 1988.

First published: 2 April 2001

The following SNZ references relate to this Standard:

Project No. P 4121
Draft for comment No. DZ 4121
Printing code: 1500-2001/101/17632
Typeset by: Standards New Zealand
Printed by: Hutcheson Bowman & Stewart
